

# Waters 2996 PDA Detector

## *Operator's Guide*

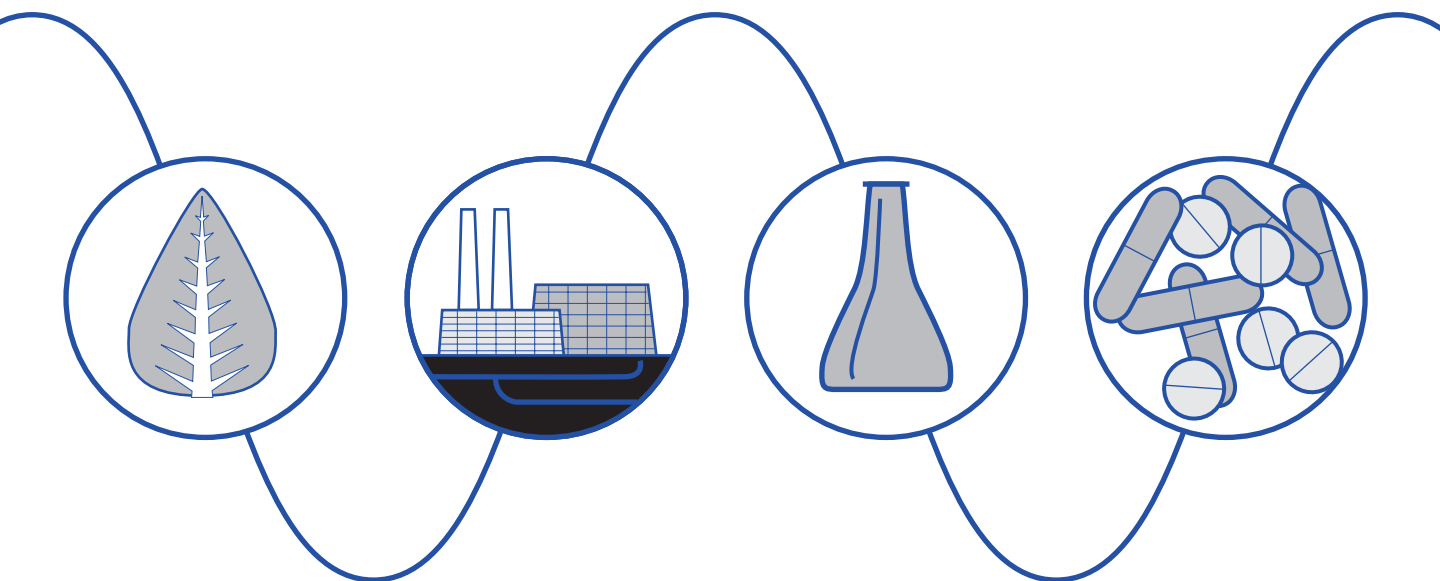

Waters

34 Maple Street  
Milford, MA 01757

71500023202, Revision B

# NOTICE

---

The information in this document is subject to change without notice and should not be construed as a commitment by Waters Corporation. Waters Corporation assumes no responsibility for any errors that may appear in this document. This document is believed to be complete and accurate at the time of publication. In no event shall Waters Corporation be liable for incidental or consequential damages in connection with, or arising from, the use of this document.

© 2001 WATERS CORPORATION. PRINTED IN THE UNITED STATES OF AMERICA. ALL RIGHTS RESERVED. THIS DOCUMENT OR PARTS THEREOF MAY NOT BE REPRODUCED IN ANY FORM WITHOUT THE WRITTEN PERMISSION OF THE PUBLISHER.

Millennium<sup>®</sup> PIC and Waters are registered trademarks, and busLAC/E and PowerStation are trademarks of Waters Corporation.

Micromass is a registered trademark and MassLynx is a trademark of Micromass Ltd.

All other trademarks or registered trademarks are the sole property of their respective owners.



**Note:** When you use the instrument, follow generally accepted procedures for quality control and methods development.

If you observe a change in the retention of a particular compound, in the resolution between two compounds, or in peak shape, immediately determine the reason for the changes. Until you determine the cause of a change, do not rely on the separation results.

**Note:** The Installation Category (Overvoltage Category) for this instrument is Level II. The Level II Category pertains to equipment that receives its electrical power from a local level, such as an electrical wall outlet.



**Attention:** Changes or modifications to this unit not expressly approved by the party responsible for compliance could void the user's authority to operate the equipment.

**Important :** Toute modification sur cette unité n'ayant pas été expressément approuvée par l'autorité responsable de la conformité à la réglementation peut annuler le droit de l'utilisateur à exploiter l'équipement.

**Achtung:** Jedwede Änderungen oder Modifikationen an dem Gerät ohne die ausdrückliche Genehmigung der für die ordnungsgemäße Funktionstüchtigkeit verantwortlichen Personen kann zum Entzug der Bedienungsbezugnis des Systems führen.

**Avvertenza:** eventuali modifiche o alterazioni apportate a questa unità e non espressamente approvate da un ente responsabile per la conformità annulleranno l'autorità dell'utente ad operare l'apparecchiatura.

**Atención:** cualquier cambio o modificación realizado a esta unidad que no haya sido expresamente aprobado por la parte responsable del cumplimiento puede anular la autorización de la que goza el usuario para utilizar el equipo.



**Caution:** Use caution when working with any polymer tubing under pressure:

- Always wear eye protection when near pressurized polymer tubing.
- Extinguish all nearby flames.
- Do not use Tefzel tubing that has been severely stressed or kinked.
- Do not use Tefzel tubing with tetrahydrofuran (THF) or concentrated nitric or sulfuric acids.
- Be aware that methylene chloride and dimethyl sulfoxide cause Tefzel tubing to swell, which greatly reduces the rupture pressure of the tubing.

**Attention :** soyez très prudent en travaillant avec des tuyaux de polymères sous pression :

- Portez toujours des lunettes de protection quand vous vous trouvez à proximité de tuyaux de polymères.
- Eteignez toutes les flammes se trouvant à proximité.
- N'utilisez pas de tuyau de Tefzel fortement abîmé ou déformé.
- N'utilisez pas de tuyau de Tefzel avec de l'acide sulfurique ou nitrique, ou du tétrahydrofurane (THT).
- Sachez que le chlorure de méthylène et le sulfoxyde de diméthyle peuvent provoquer le gonflement des tuyaux de Tefzel, diminuant ainsi fortement leur pression de rupture.

**Vorsicht:** Bei der Arbeit mit Polymerschläuchen unter Druck ist besondere Vorsicht angebracht:

- In der Nähe von unter Druck stehenden Polymerschläuchen stets Schutzbrille tragen.
- Alle offenen Flammen in der Nähe löschen.
- Keine Tefzel-Schläuche verwenden, die stark geknickt oder überbeansprucht sind.
- Tefzel-Schläuche nicht für Tetrahydrofuran (THF) oder konzentrierte Salpeter- oder Schwefelsäure verwenden.
- Durch Methylenchlorid und Dimethylsulfoxid können Tefzel-Schläuche quellen; dadurch wird der Berstdruck des Schlauches erheblich reduziert.



**Precauzione:** prestare attenzione durante le operazioni con i tubi di polimero sotto pressione:

- Indossare sempre occhiali da lavoro protettivi nei pressi di tubi di polimero pressurizzati.
- Estinguere ogni fonte di ignizione circostante.
- Non utilizzare tubi Tefzel soggetti a sollecitazioni eccessive o incurvati.
- Non utilizzare tubi Tefzel contenenti tetraidrofurano (THF) o acido solforico o nitrico concentrato.
- Tenere presente che il cloruro di metilene e il dimetilsolfossido provocano rigonfiamento nei tubi Tefzel, che riducono notevolmente il limite di pressione di rottura dei tubi stessi.

**Advertencia:** manipular con precaución los tubos de polimero bajo presión:

- Protegerse siempre los ojos a proximidad de tubos de polimero bajo presión.
- Apagar todas las llamas que estén a proximidad.
- No utilizar tubos Tefzel que hayan sufrido tensiones extremas o hayan sido doblados.
- No utilizar tubos Tefzel con tetrahidrofurano o ácidos nítrico o sulfúrico concentrados.
- No olvidar que el cloruro de metileno y el óxido de azufre dimetilo inflan los tubos Tefzel lo que reduce en gran medida la presión de ruptura de los tubos.



**Caution:** *The user shall be made aware that if the equipment is used in a manner not specified by the manufacturer, the protection provided by the equipment may be impaired.*

**Attention :** *L'utilisateur doit être informé que si le matériel est utilisé d'une façon non spécifiée par le fabricant, la protection assurée par le matériel risque d'être défectueuses.*

**Vorsicht:** *Der Benutzer wird darauf aufmerksam gemacht, dass bei unsachgemäßer Verwendung des Gerätes unter Umständen nicht ordnungsgemäß funktionieren.*

**Precauzione:** *l'utente deve essere al corrente del fatto che, se l'apparecchiatura viene usata in un modo specificato dal produttore, la protezione fornita dall'apparecchiatura potrà essere invalidata.*

**Advertencia:** *El usuario deberá saber que si el equipo se utiliza de forma distinta a la especificada por el fabricante, las medidas de protección del equipo podrían ser insuficientes.*



**Caution:** *To protect against fire hazard, replace fuses with those of the same type and rating.*

**Attention :** *Remplacez toujours les fusibles par d'autres du même type et de la même puissance afin d'éviter tout risque d'incendie.*

**Vorsicht:** *Zum Schutz gegen Feuergefahr die Sicherungen nur mit Sicherungen des gleichen Typs und Nennwertes ersetzen.*

**Precauzione:** *per una buona protezione contro i rischi di incendio, sostituire i fusibili con altri dello stesso tipo e amperaggio.*

**Precaución:** *sustituya los fusibles por otros del mismo tipo y características para evitar el riesgo de incendio.*



**Caution:** *To avoid possible electrical shock, power off the instrument and disconnect the power cord before servicing the instrument.*







**Attention :** *Afin d'éviter toute possibilité de commotion électrique, mettez hors tension l'instrument et débranchez le cordon d'alimentation de la prise avant d'effectuer la maintenance de l'instrument.*

**Vorsicht:** *Zur Vermeidung von Stromschlägen sollte das Gerät vor der Wartung abgeschaltet und vom Netz getrennt werden.*

**Precauzione:** *per evitare il rischio di scossa elettrica, spegnere lo strumento e scollegare il cavo di alimentazione prima di svolgere la manutenzione dello strumento.*



**Precaución:** *para evitar choques eléctricos, apague el instrumento y desenchufe el cable de alimentación antes de realizar cualquier reparación en el instrumento.*

## Commonly Used Symbols

	<p>Direct current          Courant continu          Gleichstrom          Corrente continua          Corriente continua</p>
	<p>Alternating current          Courant alternatif          Wechselstrom          Corrente alternata          Corriente alterna</p>
	<p>Protective conductor terminal          Borne du conducteur de protection          Schutzleiteranschluss          Terminale di conduttore con protezione          Borne del conductor de tierra</p>
	<p>Frame or chassis terminal          Borne du cadre ou du châssis          Rahmen- oder Chassisanschluss          Terminale di struttura o telaio          Borne de la estructura o del chasis</p>
	<p>Caution or refer to manual          Attention ou reportez-vous au guide          Vorsicht, oder lesen Sie das Handbuch          Prestare attenzione o fare riferimento alla guida          Actúe con precaución o consulte la guía</p>
	<p>Caution, hot surface or high temperature          Attention, surface chaude ou température élevée          Vorsicht, heiÙe OberfläÙe oder hohe Temperatur          Precauzione, superficie calda o elevata temperatura          Precaución, superficie caliente o temperatura elevada</p>
	<p>Caution, risk of electric shock (high voltage)          Attention, risque de commotion électrique (haute tension)          Vorsicht, Elektroschockgefahr (Hochspannung)          Precauzione, rischio di scossa elettrica (alta tensione)          Precaución, peligro de descarga eléctrica (alta tensión)</p>



### Commonly Used Symbols (Continued)

	<p>Caution, risk of needle-stick puncture Attention, risques de perforation de la taille d'une aiguille Vorsicht, Gefahr einer Spritzenpunktion Precauzione, rischio di puntura con ago Precaución, riesgo de punción con aguja</p>
	<p>Caution, ultraviolet light Attention, rayonnement ultraviolet Vorsicht, Ultraviolettes Licht Precauzione, luce ultravioletta Precaución, emisiones de luz ultravioleta</p>

# 2996 PDA Detector Information

---

## Intended Use

The Waters<sup>®</sup> 2996 PDA Detector can be used for in-vitro diagnostic testing to analyze many compounds, including diagnostic indicators and therapeutically monitored compounds. When you develop methods, follow the “Protocol for the Adoption of Analytical Methods in the Clinical Chemistry Laboratory,” *American Journal of Medical Technology*, 44, 1, pages 30–37 (1978). This protocol covers good operating procedures and techniques necessary to validate system and method performance.

## Biological Hazard

When you analyze physiological fluids, take all necessary precautions and treat all specimens as potentially infectious. Precautions are outlined in “CDC Guidelines on Specimen Handling,” *CDC – NIH Manual*, 1984.

## Calibration

Follow acceptable methods of calibration with pure standards to calibrate methods. Use a minimum of five standards to generate a standard curve. The concentration range should cover the entire range of quality-control samples, typical specimens, and atypical specimens.

## Quality Control

Routinely run three quality-control samples. Quality-control samples should represent subnormal, normal, and above-normal levels of a compound. Ensure that quality-control sample results are within an acceptable range, and evaluate precision from day to day and run to run. Data collected when quality-control samples are out of range may not be valid. Do not report this data until you ensure that chromatographic system performance is acceptable.

# Table of Contents

---

Preface .....	16
<b>Chapter 1</b>	
<b>Installation .....</b>	<b>20</b>
1.1 Installation Site Requirements .....	20
1.2 Power Connections.....	21
1.3 Millennium <sup>32</sup> Workstation Connections.....	22
1.3.1 Connecting the IEEE-488 Cable.....	23
1.3.2 Setting the IEEE-488 Address.....	24
1.4 Non-IEEE-488 Communication Connections.....	25
1.4.1 Connecting Analog Output Cables .....	25
1.4.2 Connecting Event Cables .....	26
1.5 Fluidic Connections.....	28
1.6 Starting Up and Shutting Down the Detector .....	30
<b>Chapter 2</b>	
<b>Diagnostics and Calibration .....</b>	<b>33</b>
2.1 Diagnostics .....	33
2.2 User-Initiated Diagnostics .....	35
2.3 PDA Calibration .....	36
<b>Chapter 3</b>	
<b>Maintenance .....</b>	<b>37</b>
3.1 Flow Cell Maintenance.....	37
3.1.1 Flushing the Flow Cell .....	37

3.1.2 Removing the Flow Cell.....	38
3.1.3 Disassembling and Cleaning the Flow Cell .....	40
3.1.4 Installing the Flow Cell Assembly .....	42
3.2 Replacing the Lamp .....	43
3.3 Replacing the Fuses .....	45

## Chapter 4

Principles of the 2996 PDA Detector Optics .....	47
4.1 2996 Detector Optics .....	47
4.2 Resolving Spectral Data .....	49
4.3 Measuring Light at the Photodiode .....	50
4.4 Computing Absorbance Data Points .....	53
4.4.1 Calculating Absorbance.....	53
4.4.2 Resolution.....	56
4.4.3 Filtering Data .....	56

## Chapter 5

Spectral Contrast Theory .....	58
5.1 Comparing Absorbance Spectra.....	58
5.2 Representing Spectra as Vectors .....	59
5.2.1 Vectors Derived from Two Wavelengths .....	60
5.2.2 Vectors Derived from Multiple Wavelengths .....	60
5.3 Spectral Contrast Angles .....	61
5.4 Undesirable Effects.....	64
5.4.1 Detector Noise .....	64
5.4.2 Photometric Error.....	65
5.4.3 Solvent Changes .....	65

5.4.4 Threshold Angle.....	65
Appendix A Detector Specifications.....	67
Appendix B Spare Parts.....	68
Appendix C Mobile Phase Absorbance.....	69
Index .....	73

# List of Figures

---

1-1	Waters 2996 PDA Detector Dimensions.....	21
1-2	Detector Rear Panel .....	22
1-3	Example of IEEE-488 Cable Connections .....	23
1-4	Locating the IEEE-488 Switches .....	24
1-5	Analog Out Terminal Strip.....	26
1-6	Event Input/Output Terminal Strip.....	27
1-7	Compression Screw Assembly .....	29
1-8	2996 Detector Indicator Lights.....	31
3-1	Removing the Flow Cell Assembly .....	39
3-2	Flow Cell and Fluidic Connections Assemblies .....	40
3-3	Disassembling the Flow Cell.....	41
3-4	Lamp Power Connector and Mounting Screws .....	44
3-5	Fuse Block.....	45
4-1	Optics Assembly Light Path.....	48
4-2	Benzene Spectrum at 1.2 nm Resolution .....	50
4-3	Photodiodes Discharged by Light.....	51
4-4	Absorbance as a Function of Concentration.....	54
5-1	Comparing Spectra of Two Compounds.....	59
5-2	Plotting Vectors for Two Spectra.....	60
5-3	Spectra with a Large Spectral Contrast Angle.....	62
5-4	Spectra with a Small Spectral Contrast Angle.....	63
5-5	Absorbance Spectra of a Compound at Two Concentrations.....	64
5-6	Effects of pH and Solvent Concentration on the Absorbance Spectrum of <i>p</i> -Aminobenzoic Acid.....	66

# List of Tables

---

1-1	Site Requirements .....	20
1-2	Event In Terminal Specifications on TTL or Switch Closure .....	28
1-3	Event Out Terminal Specifications on Contact Closure .....	28
1-4	LED Indicator Sequences During Startup .....	31
2-1	2996 Detector Troubleshooting .....	33
4-1	Optics Assembly Components .....	48
A-1	2996 Detector Specifications .....	67
B-1	Spare Parts .....	68
C-1	Mobile Phase Absorbance Measured Against Air or Water .....	69

# Preface

---

The *Waters 2996 PDA Detector Operator's Guide* describes the procedures for installing, maintaining, and troubleshooting the Waters® 2996 PDA Detector. It also describes detector optics and the principles of Spectral Contrast used in the Millennium®<sup>32</sup> software for analyzing the data from the PDA detector. Also included is information on vector analysis, mobile phase absorbance, specifications.

This guide is intended for individuals who need to install, operate, maintain, and troubleshoot the 2996 PDA Detector. It is also intended for users who need to understand the Spectral Contrast principles underlying the processing of PDA Detector data by Millennium<sup>32</sup> software.

## Organization

This guide contains the following:

[Chapter 1](#) describes how to install and set up the 2996 Detector.

[Chapter 2](#) describes how to troubleshoot the 2996 Detector.

[Chapter 3](#) describes how to replace the flow cell, the lamp, and the fuse.

[Chapter 4](#) explains the principles involved in resolving spectral data, measuring light at the photodiode, verifying wavelengths, and computing absorbance data.

[Chapter 5](#) describes the calculations used for Spectral Contrast.

[Appendix A](#) provides the specifications of the 2996 PDA Detector.

[Appendix B](#) lists recommended spare parts.

[Appendix C](#) provides a table of absorbances at several wavelengths for common mobile phases.

## Related Documents

***Waters Licenses, Warranties, and Support:*** Provides software license and warranty information, describes training and extended support, and tells how Waters handles shipments, damages, claims, and returns.

***Millennium<sup>32</sup> Help:*** Describes all Millennium<sup>32</sup> windows, menus, menu selections, and dialog boxes. Also includes reference information and procedures for performing all tasks required to use the Millennium<sup>32</sup> software. Included as part of the Millennium<sup>32</sup> software.



**Millennium<sup>32</sup> Software Getting Started Guide:** Provides an introduction to the Millennium<sup>32</sup> System. Describes the basics of how to use Millennium<sup>32</sup> software to acquire data, develop a processing method, review results, and print a report. Also covers basics for managing projects and configuring systems.

**Millennium<sup>32</sup> PDA Software Getting Started Guide:** Describes the basics of how to use Millennium<sup>32</sup> PDA software to develop a PDA processing method and to review PDA results.

**Millennium<sup>32</sup> System Installation and Configuration Guide:** Describes Millennium<sup>32</sup> software installation, including the stand-alone workstation, PowerStation™ system, and client/server system. Discusses how to configure the computer and chromatographic instruments as part of the Millennium<sup>32</sup> system. Also covers the installation, configuration, and use of acquisition servers such as the LAC/E<sup>32</sup> module, the busLAC/E card, and interface cards used to communicate with serial instruments

**Waters 2996 PDA Detector Qualification Workbook:** Describes qualification procedures for the 2996 PDA Detector.

## Related Adobe Acrobat Reader Documentation

For detailed information about using Adobe® Acrobat® Reader, refer to the *Adobe Acrobat Reader Online Guide*. This Online Guide covers procedures such as viewing, navigating, and printing electronic documentation from Adobe Acrobat Reader.

## Printing This Electronic Document

Adobe Acrobat Reader lets you easily print pages, page ranges, or the entire document by selecting **Print** from the File menu. For optimum print quantity, Waters recommends that you specify a PostScript® printer driver for your printer. Ideally, use a printer that supports 600 dpi print resolution.

## Documentation Conventions

The following conventions may be used in this guide:

Convention	Usage
<b>Purple</b>	Purple text indicates user action such as keys to press, menu selections, and commands. For example, “Click <b>Next</b> to go to the next page.”
<i>Italic</i>	Italic indicates information that you supply such as variables. It also indicates emphasis and document titles. For example, “Replace <i>file_name</i> with the actual name of your file.”

Convention	Usage
Courier	Courier indicates examples of source code and system output. For example, “The SVRMGR> prompt appears.”
<b>Courier Bold</b>	Courier bold indicates characters that you type or keys you press in examples of source code. For example, “At the LSNRCTL> prompt, enter <b>set password oracle</b> to access Oracle.”
<u>Underlined blue</u>	Indicates hypertext cross-references to a specific chapter, section, subsection, or sidehead. Clicking this topic using the hand symbol automatically brings you to this topic within the document. Right-clicking and selecting <b>Go Back</b> from the shortcut menu returns you to the originating topic. For example: Polarity connections are described in <a href="#">Section 3.3.6, Polarity Connections</a> .
Keys	The word <i>key</i> refers to a computer key on the keypad or keyboard. <i>Screen keys</i> refer to the keys on the instrument located immediately below the screen. For example, “The A/B screen key on the 2414 Detector displays the selected channel.”
...	Three periods indicate that more of the same type of item can optionally follow. For example, “You can store <i>filename1</i> , <i>filename2</i> , ... in each folder.”
>	A right arrow between menu options indicates you should choose each option in sequence. For example, “Select <b>File &gt; Exit</b> ” means you should select <b>File</b> from the menu bar, then select <b>Exit</b> from the File menu.

## Notes

Notes call out information that is helpful to the operator. For example:

**Note:** *Record your result before you proceed to the next step.*

## Attentions

Attentions provide information about preventing possible damage to the system or equipment. For example:



**Attention:** *To avoid damaging the detector flow cell, do not touch the flow cell window.*

## Cautions

Cautions provide information essential to the safety of the operator. For example:



**Caution:** To avoid possible burns, turn off the lamp at least 15 minutes before removing it for replacement or adjustment.



**Caution:** To avoid possible electrical shock and injury, always turn off the detector and unplug the power cord before performing maintenance procedures.



**Caution:** To avoid chemical or electrical hazards, always observe safe laboratory practices when operating the system.

# Chapter 1

## Installation

The Waters<sup>®</sup> 2996 Photodiode Array (PDA) Detector operates in any standard laboratory environment. The detector requires electrical power, sample and waste fluidic lines, and either the Millennium<sup>®32</sup> or MassLynx<sup>™</sup> workstations. Optional connections on the detector rear panel allow communication with chart recorders, data integrators, and other instruments that are not compatible with Millennium<sup>32</sup> or MassLynx software control.

### 1.1 Installation Site Requirements

Install the 2996 PDA Detector at a site that meets the specifications in [Table 1-1](#).

Table 1-1 Site Requirements

Factor	Specification
Ambient temperature	4 to 40 °C (39 to 104 °F), not to vary more than 1 °C per hour (to prevent drift)
Relative humidity	20 to 80%, noncondensing
Bench space	Width: 11.5 in. (29 cm) Depth: 24 in. (61 cm) Height: 8.125 in. (22 cm)
Bench support	Capable of supporting 31.5 pounds (14.3 kg)
Clearance	At least 4 in. (10 cm) on the back side for ventilation

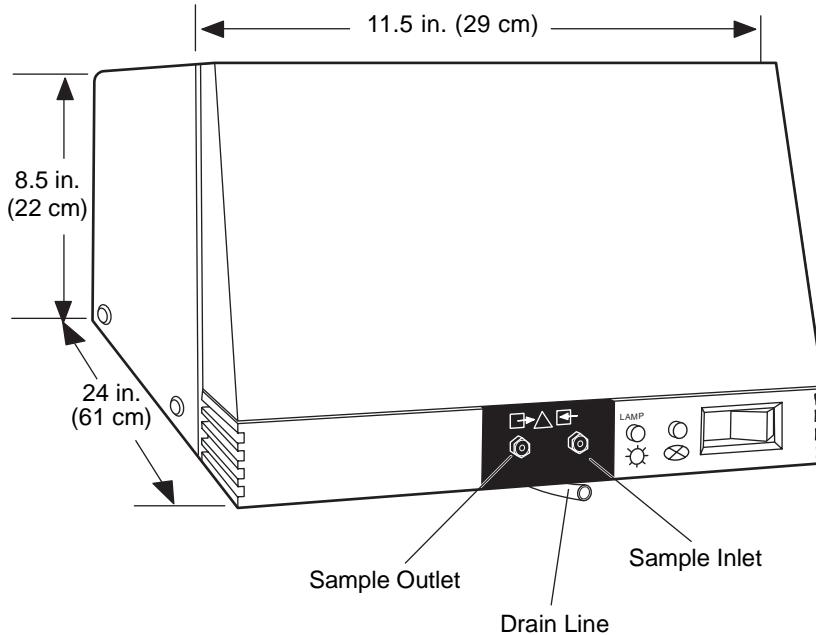

Figure 1-1 Waters 2996 PDA Detector Dimensions

## 1.2 Power Connections

Ensure that power connections for the 2996 PDA Detector are made according to the procedures that follow.

### Operating Voltage

The 2996 PDA Detector has a universal input power supply that requires no voltage adjustment. The electrical power requirements for the Waters 2996 PDA Detector are:

- **Voltage range:** 100 to 240 Vac
- **Total power:** 100 VA
- **Frequency range:** 50 to 60 Hz

### Fuses

The 2996 PDA Detector is shipped with fuses rated for North American operation. If you operate the 2996 PDA Detector in another location, install the IEC-rated fuses (supplied in

the Waters 2996 Detector Startup Kit) in the fuse holder in the rear of the detector (refer to [Section 3.3, Replacing the Fuses](#)).

## Connecting the Power Cord

Connect one end of the 2996 Detector power cord to the rear panel power receptacle (Figure 1-2) and the other end to a power outlet.

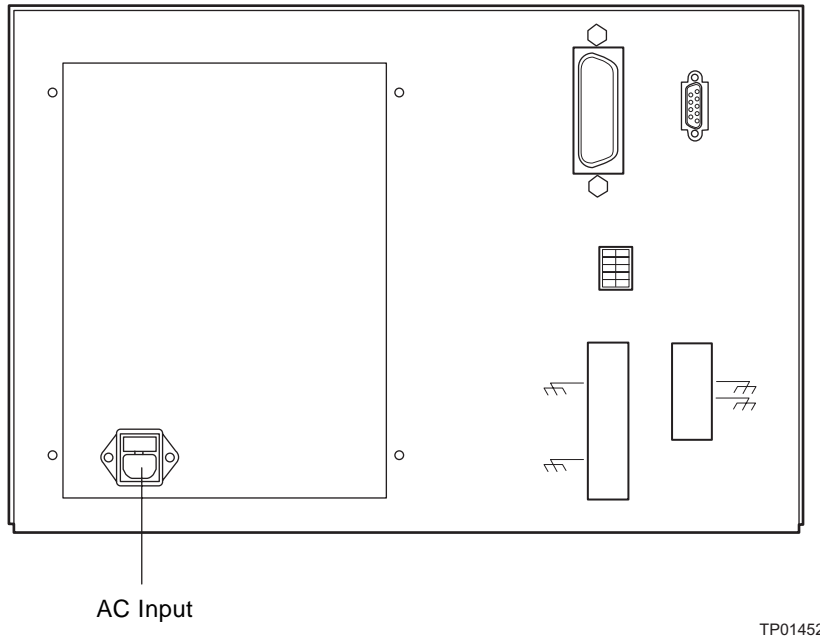

Figure 1-2 Detector Rear Panel

## 1.3 Millennium<sup>32</sup> Workstation Connections

The 2996 Detector requires signal connections to the Millennium<sup>32</sup> Workstation over the IEEE-488 bus. All detector control and data acquisition communications take place over the IEEE-488 bus.

**Note:** If an inject start signal is not available over the IEEE-488 bus, you must provide a signal at the Event In 1 terminals on the 2996 Detector rear panel ([Section 1.4.2, Connecting Event Cables](#)).

### 1.3.1 Connecting the IEEE-488 Cable

To connect the 2996 Detector to a Millennium<sup>32</sup> Workstation:

1. Connect one end of the IEEE-488 cable to the IEEE-488 receptacle on the rear panel of the 2996 Detector. Connect the other end of the cable (stackable connector for daisy-chaining additional instruments) to the IEEE-488 connector on any of the other instruments in your chromatographic system ([Figure 1-3](#)).

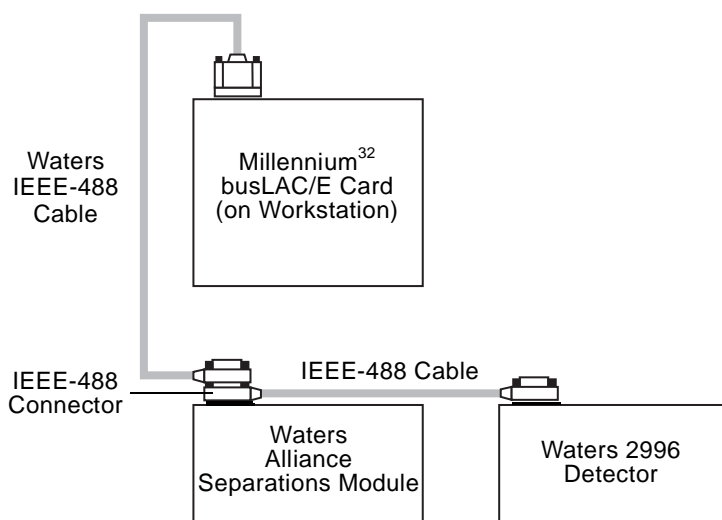

TP01544

Figure 1-3 Example of IEEE-488 Cable Connections

**Note:** The order in which you connect IEEE-488 devices to the busLAC/E card on the workstation is not important. For example, you can connect the 2690 Separations Module before or after the 2996 Detector.

2. Use another IEEE-488 cable to connect to the stackable connector on the first instrument and the IEEE-488 connector on another instrument.
3. Repeat step 2 for each IEEE-488 instrument in your chromatographic system, up to a maximum of 14 IEEE-488 instruments.

**Note:** Keep in mind cable-length limitations when you set up your system. For a list of IEEE-488 interface guidelines, refer to the Millennium<sup>32</sup> System Installation and Configuration Guide.

4. Ensure that all IEEE-488 cable screws are fastened finger-tight.

## Cable Lengths

The maximum length of all cables connecting instruments to one busLAC/E is 2 meters multiplied by the number of devices (or 20 meters, whichever is smaller).

The maximum length of cable between devices is 4 meters.

**Note:** The maximum number of devices to be connected together is 14.

### 1.3.2 Setting the IEEE-488 Address

To set the IEEE-488 address for the 2996 Detector:

Use a small screwdriver (or similar device) to set the IEEE-488 switches on the detector rear panel (Figure 1-4) to the IEEE-488 address of the 2996 Detector. The address must be a number from 2 to 29 and must be different than that of any other component connected to your acquisition server.

Refer to the *Millennium<sup>32</sup> System Installation and Configuration Guide* for the correct IEEE-488 GPIB switch settings.

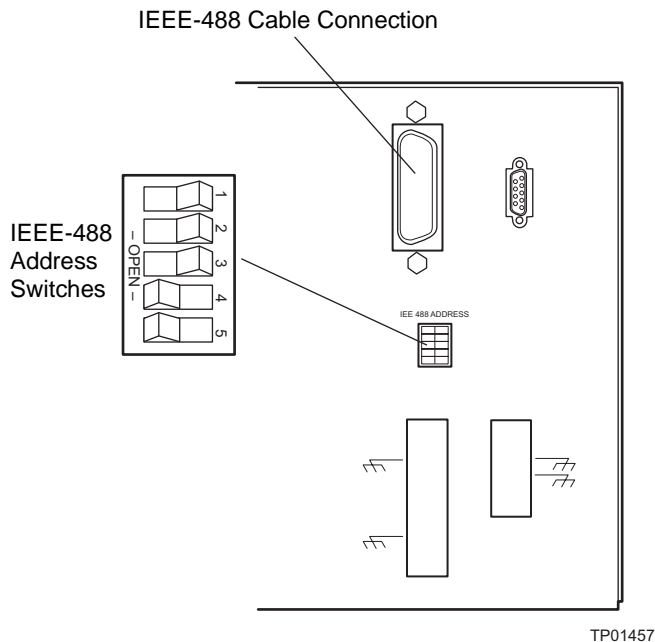

Figure 1-4 Locating the IEEE-488 Switches



## 1.4 Non-IEEE-488 Communication Connections

Non-IEEE-488 communication connections on the 2996 Detector include:

- **Analog Outputs** – The 2996 Detector provides two, unattenuated, 1 volt-per absorbance-unit analog output channels to integrators, chart recorders, or other components.
- **Event Inputs and Outputs** – The 2996 Detector sends and receives contact closure signals to and from other instruments.

You make all non-IEEE-488 communication cable connections to the 2996 Detector at the rear panel on the analog/event terminal ([Figure 1-2](#)).



**Attention:** To meet the regulatory requirements of immunity from external electrical disturbances that may affect the performance of this instrument, do not use cables longer than 9.8 feet (3 meters) when you make connections to the screw-type barrier terminal strips. In addition, ensure that you always connect the shield of each cable to chassis ground.

### 1.4.1 Connecting Analog Output Cables

The values of the analog output signals generated by the 2996 Detector are specified by parameter values set from the Millennium<sup>32</sup> Workstation. For details, refer to the Millennium<sup>32</sup> Help.

#### Required Materials

- One small, flat-blade screwdriver
- One electrical insulation stripping tool
- Analog signal cables (included with the Waters 2996 Detector Startup Kit)

#### Procedure

To connect the 2996 Detector to a device that receives analog output signals:

1. Pull off the analog out terminal strip from the 2996 Detector rear panel ([Figure 1-5](#)). This step simplifies the following steps.
2. Insert the appropriate bare wires at one end of an analog signal cable into the positive (+) and negative (–) terminals of Analog Out 1 ([Figure 1-5](#)). Tighten the two screws to secure the + and – wires.
3. Connect the other end of the analog signal cable to the appropriate analog input terminal on the external device, being sure to maintain negative-to-negative and positive-to-positive continuity.

4. Reinstall the Analog Output Terminal strip.

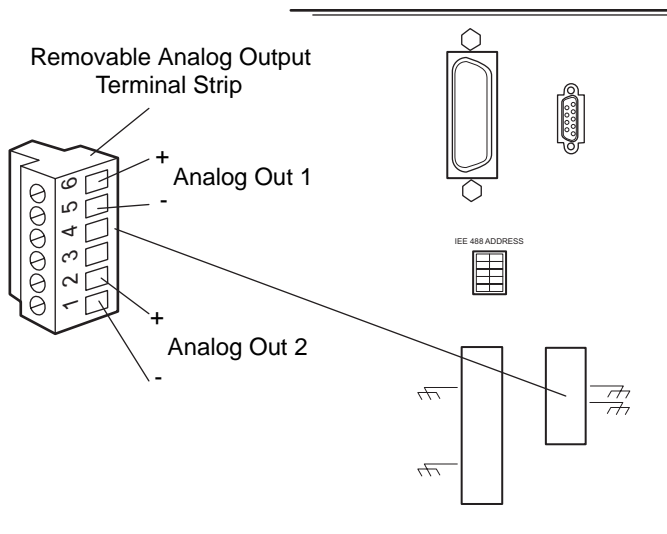

TP01456

Figure 1-5 Analog Out Terminal Strip

## 1.4.2 Connecting Event Cables

The 2996 Detector has four terminal strip connections for contact closure signals:

- Two input signal terminals (generally used for inject start)
- Two output (programmable event table) signal terminals

If an inject start signal is not available over the IEEE-488 bus, you must provide a signal at Event In 1 terminal on the 2996 Detector rear panel. Manual injectors such as the Rheodyne 7725i provide a cable that connects the injector to an Event In terminal on the 2996 Detector rear panel.

The values of the event output signals generated by the 2996 Detector are specified by parameter values set from the Millennium<sup>32</sup> Workstation. For details, refer to the *Millennium<sup>32</sup> Help*.

### Required Materials

- Small flat-blade screwdriver
- One electrical insulation stripping tool
- Event signal cables (included in the Waters 2996 Detector Startup Kit)

## Procedure

To connect the 2996 Detector to an external event input or output device:

Pull off the event terminal strip from the rear panel ([Figure 1-6](#)). This simplifies the following steps:

1. Insert the bare wires at one end of the event signal cable into the positive (+) and negative (-) slots of the appropriate event input or output terminal ([Figure 1-6](#)). Tighten the two screws to secure the + and - wires.
2. Connect the other end of the event signal cable to the appropriate event input or event output terminal on the external device.
3. Reinstall the event terminal strip.

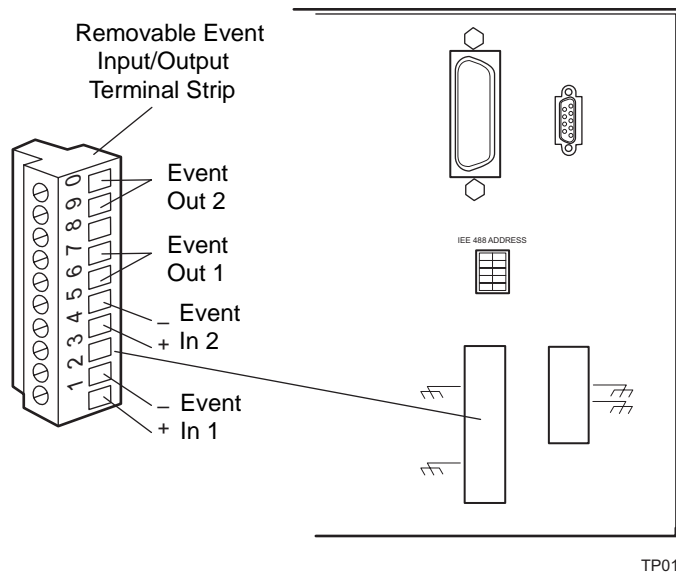

Figure 1-6 Event Input/Output Terminal Strip

## Electrical Specifications

Before you connect an external device to an event input or output terminal, refer to the electrical specifications in [Table 1-2](#) and [Table 1-3](#).

Table 1-2 Event In Terminal Specifications on TTL or Switch Closure

Parameter	Specification
Low trigger	<1.8 V
High trigger	>3.0 V
Protected to	±30 V
Minimum pulse width	30 msec (this may limit compatibility with valves that require a quick pulse)
Maximum current	5 mA

Table 1-3 Event Out Terminal Specifications on Contact Closure

Parameter	Specification
Maximum power	10 W
Maximum current	0.5 A at 20 V
Maximum voltage	24 V RMS



**Attention:** To avoid damage to the 2996 Detector electronics, be sure you make the proper electrical connections as outlined in this section.

## 1.5 Fluidic Connections



**Caution:** To avoid chemical hazards, always observe safe laboratory practices when handling solvents. Refer to the Material Safety Data Sheets for the solvents in use.

### Required Materials

- 5/16-inch open-end wrench
- 0.009-inch (0.23 mm) ID stainless steel tubing (included in the 2996 Detector Startup Kit)
- Stainless steel tubing cutter or scribing file

- Pliers, plastic-covered, or with cloth
- Compression screw assemblies, three

## Procedure

To make fluidic connections to the 2996 Detector:

1. Measure the lengths of tubing needed to connect:
  - The column outlet to the 2996 Detector inlet

**Note:** *Keep the length of this tubing as short as possible to prevent band broadening.*

- The 2996 Detector outlet to a waste collection bottle

**Note:** *Ensure the length of this tubing is at least 1 to 2 feet (30 to 60 cm) to prevent air bubbles from forming in the flow cell.*

2. Cut the two lengths of tubing as follows:
  - a. Use a Waters 1/16-inch stainless steel tubing cutter or a file with a cutting edge to scribe the circumference of the tubing at the desired break point.
  - b. Grasp the tubing on both sides of the scribed mark with cloth- or plastic-covered pliers (to prevent marring the surface), then gently work the tubing back and forth until it separates.
  - c. File the tubing ends smooth and straight to minimize dead volume and band broadening.
3. Assemble a compression fitting (Figure 1-7) at both ends of the column outlet line and at one end of the detector outlet line.

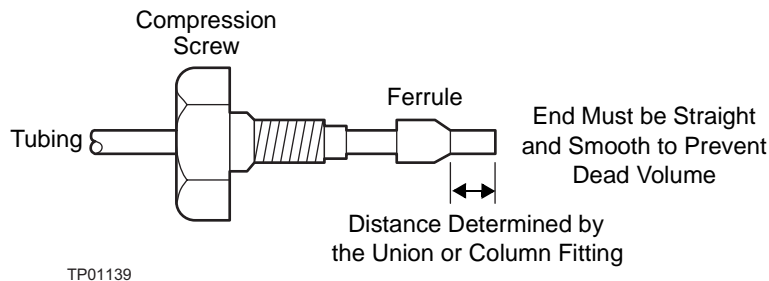

Figure 1-7 Compression Screw Assembly

4. Seat one end of the column outlet tubing in the fitting of the column outlet, then tighten the compression screw about 3/4-turn past finger-tight (using the 5/16-inch open-end wrench).
5. Seat the other end of the tubing in the fitting of the detector inlet, then tighten the compression screw as in step 4.
6. Seat the end of the detector outlet tubing with the compression fitting in the detector outlet fitting, then tighten the compression screw about 3/4-turn past finger-tight. Insert the other end of the tubing in the waste container.



**Attention:** To avoid damage to the flow cell, avoid pressures approaching its maximum allowable pressure, 1000 psi (70 kg/cm<sup>2</sup>).

## 1.6 Starting Up and Shutting Down the Detector

---

The entire startup procedure takes less than 1 minute. Once completed, you should allow the 2996 Detector to warm up for at least 1 hour before running an analysis. Follow the procedures in this section to ensure reliable detector performance.

### Starting Up the Detector

To start up the 2996 Detector:

1. In your instrument method, set the solvent delivery system or pump to deliver 1 mL/min of degassed mobile phase. For details, refer to the *Millennium<sup>32</sup> Help*.

**Note:** Use only thoroughly degassed HPLC-grade solvents. Gas in the mobile phase may form bubbles in the flow cell and cause the detector to fail the Reference Energy diagnostic.

2. Flush the detector for 10 minutes or until no bubbles appear in the outlet line.
3. Press the **0/1** (Off/On) switch on the front panel of the detector ([Figure 1-8](#)) to the **1** (On) position.
4. Observe the Lamp and Status indicator LEDs on the front panel of the detector ([Figure 1-8](#)).
  - If both lights remain illuminated, the detector passed the internal diagnostics.
  - If either indicator light blinks or is off, refer to the troubleshooting tables in [Chapter 2, Diagnostics and Calibration](#).
5. Wait 1 hour for the 2996 Detector to stabilize before acquiring data.

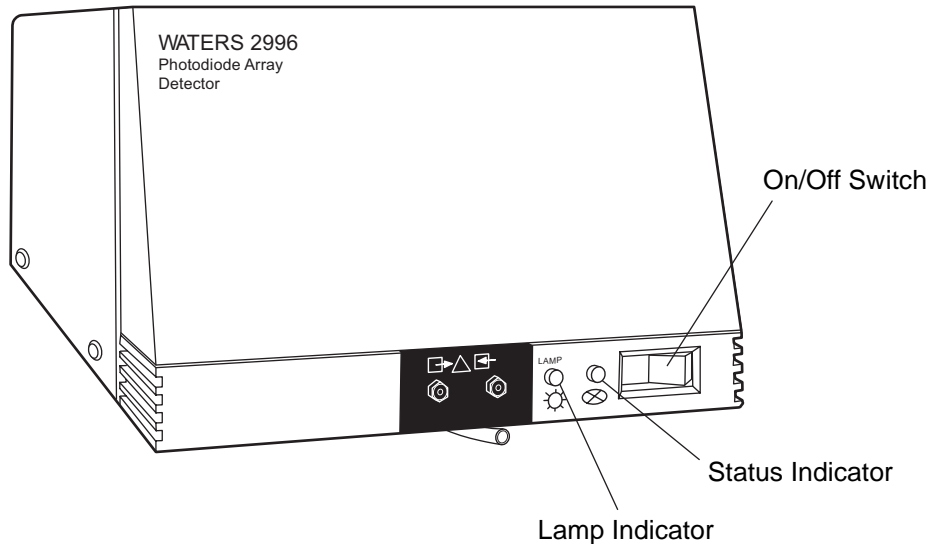

TP01460

Figure 1-8 2996 Detector Indicator Lights

Table 1-4 LED Indicator Sequences During Startup

Lamp LED	Status LED	Indicates	Troubleshooting
OFF	OFF	No power or CPU failure.	Check ac source and main fuse. Contact Waters Technical Service.
OFF	FLASHING	The 2996 is running power-on self-tests.	
FLASHING	FLASHING	2996 has failed one of the self-tests.	Contact Waters Technical Service.
OFF	FLASHING	The 2996 is running Confidence tests.	
ON	FLASHING	Lamp start was successful. The 2996 is starting calibration.	
ON	FLASHING for more than 30 seconds	The 2996 may not have calibrated correctly.	Could be air bubble in flow cell ( <a href="#">Table 2-1</a> ) Contact Waters Technical Service.

Table 1-4 LED Indicator Sequences During Startup (*Continued*)

Lamp LED	Status LED	Indicates	Troubleshooting
ON	ON	Calibration was successful.	

## Shutting Down the Detector

To shut down the 2996 Detector:

1. If the mobile phase contains buffers, set the solvent delivery system or pump to deliver 1 mL/min of HPLC-grade water for 10 minutes. Otherwise, set the solvent delivery system or pump to deliver 1 mL/min of degassed methanol for 10 minutes.
2. Press the **0/1** (Off/On) switch on the front panel of the detector to the **0** (Off) position.



# Chapter 2

## Diagnostics and Calibration

The Waters 2996 Photodiode Array Detector automatically runs a series of internal diagnostics upon start up. The indicator LEDs on the front of the detector and messages at the Millennium<sup>32</sup> Workstation show the results of the start up internal diagnostics ([Figure 1-8](#)).

If you need to determine the cause of a problem during operation of the detector, you can run the same internal diagnostics from the Millennium<sup>32</sup> Workstation. Additional information about the performance of the detector is also available through the PDA Calibration window, accessed from Run Samples in the Millennium<sup>32</sup> software.

If you encounter a problem that you cannot troubleshoot ([Section 2.1, Diagnostics](#)), contact Waters Technical Service at (800) 252-4752, *U.S. and Canadian customers only*. Other customers, call your local Waters subsidiary or your local Waters Technical Service Representative in Milford, Massachusetts (U.S.A.) for assistance.

### 2.1 Diagnostics

Refer to [Table 2-1](#) to troubleshoot problems encountered during startup diagnostics and during detector operation.

Table 2-1 2996 Detector Troubleshooting

Symptom	Possible Cause	Corrective Action
Both LEDs off	No power	1. Check line cord connections. 2. Check outlet for power.
	Blown fuse	Replace fuse ( <a href="#">Section 3.3, Replacing the Fuses</a> ).
Status light blinks and lamp light is off	The 2996 is running Confidence tests.	

Table 2-1 2996 Detector Troubleshooting (Continued)

Symptom	Possible Cause	Corrective Action
Status light blinks and lamp light on	Failed startup diagnostics	Reseat and check alignment of flow cell.
		Flush the flow cell ( <a href="#">Section 3.1.1, Flushing the Flow Cell</a> ).
	Insufficient energy reaching photodiode array because of air bubble, or dirty flow cell can cause shutter diagnostic to fail	Flush the flow cell ( <a href="#">Section 3.1.1, Flushing the Flow Cell</a> ).
		To prevent air bubbles from forming, check that there is a 1- to 2-foot (30- to 60-cm) length of 0.009-inch (0.23-mm) ID tubing connected to the detector waste outlet.
Weak lamp	Replace lamp ( <a href="#">Section Figure 3-1, Removing the Flow Cell Assembly</a> ).	
Shutter failure message	Shutter failed	Run the Shutter diagnostic. For details, see <i>Millennium<sup>32</sup> Help</i> .
Detector not responding to Millennium <sup>32</sup> Workstation	Detector not connected to busLAC/E or to LAC/E <sup>32</sup> Acquisition Server in the Millennium <sup>32</sup> Workstation	Check IEEE-488 cable connections, tighten connectors.
	Incorrect IEEE-488 address	<ol style="list-style-type: none"> <li>1. Ensure that the 2996 Detector IEEE-488 address is unique and within the range 2 to 29 (see the <i>Millennium<sup>32</sup> System Installation and Configuration Guide</i>).</li> <li>2. Rescan the IEEE-488 bus. For details, see <i>Millennium<sup>32</sup> Help</i>.</li> </ol>

Table 2-1 2996 Detector Troubleshooting (*Continued*)

Symptom	Possible Cause	Corrective Action
Change in reference spectrum	Mobile phase contains gas or is contaminated	Prepare fresh mobile phase and degas thoroughly.
	Air bubbles trapped in flow cell	Reseat and check alignment of flow cell.
		Flush the flow cell, or apply slight back-pressure on the detector waste outlet.
		To prevent air bubbles, check that there is a 1- to 2-foot (30- to 60-cm) length of 0.009-inch (0.23-mm) ID tubing connected to the detector waste outlet.
Solvent in drain line	Leak from flow cell gasket	Rebuild flow cell with a new gasket ( <a href="#">Section 3.1.3, Disassembling and Cleaning the Flow Cell</a> ).
	Leak from flow cell fittings	Check fittings for overtightening or undertightening, and replace fittings if necessary.

## 2.2 User-Initiated Diagnostics

**Note:** The system administrator can restrict access to the 2996 Detector diagnostics by disabling user access to *Run Samples*. For details, refer to the Millennium<sup>32</sup> Help.

There are two types of user-initiated PDA diagnostic tests:

- **Internal Tests** – Tests run by the instrument firmware that help you determine the source of a malfunction. These tests do not require connections to external devices.
- **Interactive Tests** – Tests that check analog output and event input/output signal communications between the detector and connected external devices. These tests require connections to pump flow and/or test equipment.

You can run all user-initiated diagnostics from *Run Samples* in the Millennium<sup>32</sup> software. For more information on *Run Samples* and PDA diagnostics, refer to the *Millennium<sup>32</sup> Help*.

## 2.3 PDA Calibration

---

You can adjust, or calibrate, the 2996 Detector to ensure that wavelength readings are accurate. Recalibrate the 2996 Detector *only* if the Wavelength Accuracy diagnostic (in the Internal Diagnostics tests) fails. Calibration allows you to correct small errors in wavelength which may be caused by aging optics or excessive vibration.

You calibrate the 2996 detector using the PDA Calibration window, which you access from Run Samples and which allows you to:

- View the effects of exposure time on photodiode saturation for a given wavelength range.
- Verify the wavelength location of the deuterium spectrum Balmer lines (486.0 nm and 656.1 nm).
- Recalibrate to set the 486-nm peak at the proper wavelength.
- Ensure precise data for library matching.



**Attention:** *Recalibrating the wavelength requires that spectral libraries be reentered.*

**Note:** *The system administrator can restrict access to the PDA Calibration window by disabling access to Run Samples.*

**Note:** *Ensure that the flow cell is clean before you check calibration ([Section 3.1.1. Flushing the Flow Cell](#)).*

To prepare for calibration:

1. Set the pump to deliver 1 mL/min of degassed methanol for 10 minutes. If methanol is not miscible with the previous solvent, flush with a miscible solvent before switching to methanol.
2. If you have been using buffers, flush with HPLC-quality water at 1 mL/min for 10 minutes, then switch to methanol for 10 minutes.

**Note:** *Ensure that the solvent is miscible with the previous mobile phase.*

For information on performing calibration, refer to the *Millennium<sup>32</sup> Help*.

# Chapter 3

## Maintenance

---

This chapter covers maintenance of the Waters 2996 Photodiode Array Detector flow cell, lamp, and fuse.



**Caution:** To avoid possible electric shock, do not remove the 2996 Detector power supply covers. The power supply does not contain user-serviceable components.

### 3.1 Flow Cell Maintenance

---

The flow cell requires maintenance when:

- The reference spectrum changes.
- The cell fluid leaks out of the drain tube.
- The Lamp diagnostic (in the Millennium<sup>32</sup> PDA Diagnostics window) fails and the lamp status light is on ([Table 2-1](#)).
- The 2996 Detector causes high backpressure.

**Note:** Conditions other than a dirty flow cell may cause decreased lamp intensity. For more information, refer to [Chapter 2, Diagnostics and Calibration](#).

Flow cell maintenance consists of:

- Flushing the flow cell
- Removing the flow cell
- Disassembling and cleaning the flow cell
- Installing the flow cell assembly

#### 3.1.1 Flushing the Flow Cell

##### Required Materials

- HPLC-grade water
- HPLC-grade methanol

If the flow cell requires cleaning, first try flushing it with solvent.

## Procedure

To flush the flow cell:

1. Select a solvent compatible with the samples and mobile phases that you have been using. If you have been using buffers, flush with HPLC-grade water for 10 minutes at 1 mL/min, then switch to a low-surface-tension solvent such as methanol.



**Attention:** Ensure that the solvent is miscible with the previous mobile phase.

2. Set pump flow to 1 mL/min, then run the pump for 10 minutes.
3. Test the lamp energy by performing the Lamp diagnostic test. For details, refer to *Millennium<sup>32</sup> Help*.

If the lamp diagnostic fails and the lamp has not been used more than 2000 hours or 1 year (whichever comes first), disassemble the flow cell and clean the flow cell components using the procedure described in [Section 3.1.2, Removing the Flow Cell](#).

### 3.1.2 Removing the Flow Cell

**Note:** You do not need to shut down the 2996 Detector to remove and replace the flow cell.

#### Required Materials

- 5/16-inch open-end wrench
- Phillips screwdriver
- Powder-free gloves

#### Procedure

To remove the 2996 Detector flow cell:

1. Set the flow to 0.0 mL/min.
2. Power off the solvent delivery system or pump to avoid exposure to chemicals.



**Caution:** To avoid the possibility of leaking mobile phase, do not disconnect the inlet or outlet fluidic lines while there is pressure in the chromatographic system. Always vent your system before disconnecting fluidic lines.

3. Use the 5/16-inch wrench to disconnect the fluidic lines at the front of the detector.

4. Lift up the 2996 detector front cover and pull the front cover from the detector chassis.
5. Open the flow cell access door by pulling the black thumbtab, then pull the door gently toward you ([Figure 3-1](#)).

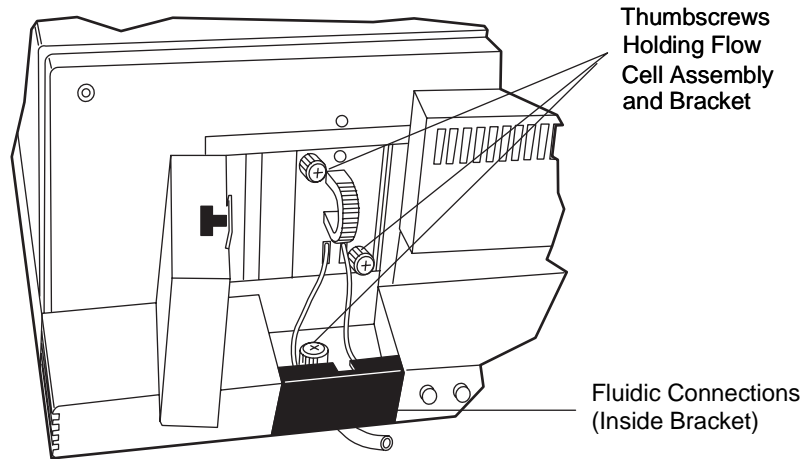

TP01462

Figure 3-1 Removing the Flow Cell Assembly

6. Use the Phillips screwdriver to loosen the three thumbscrews that hold the flow cell assembly to the optics bench and the thumbscrew that secures the bracket holding the fluidic connections, then detach the bracket.
7. Pull the flow cell assembly gently toward you to remove it from the detector ([Figure 3-2](#)).

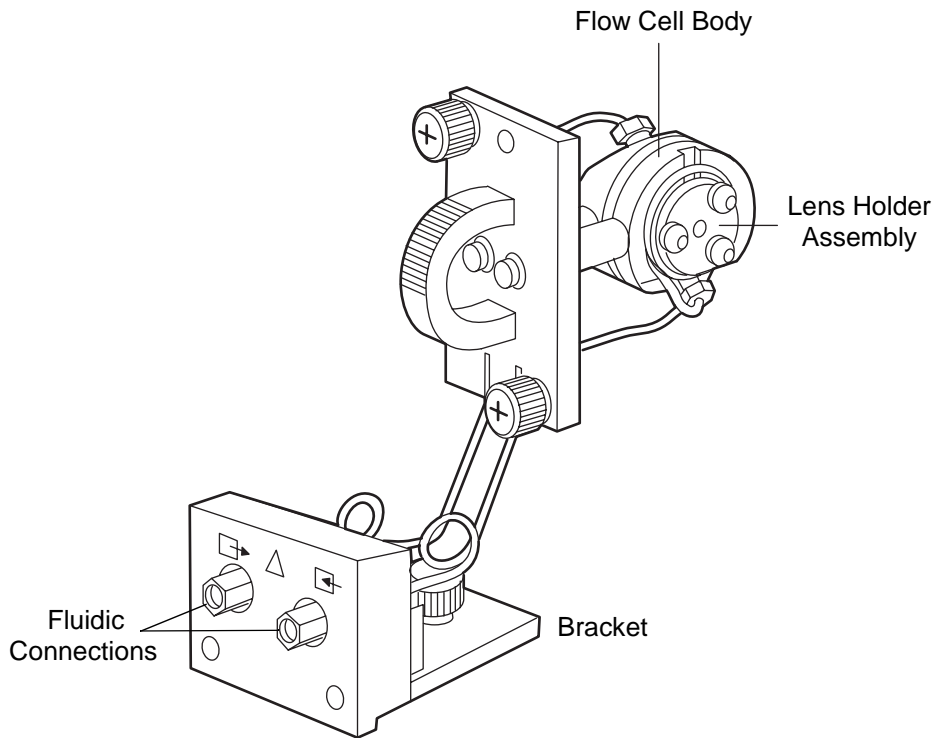

TP01463

Figure 3-2 Flow Cell and Fluidic Connections Assemblies

### 3.1.3 Disassembling and Cleaning the Flow Cell



**Attention:** *The lens surface finish and the alignment of the lenses are critical to the performance of the 2996 Detector. Be careful not to touch or damage the lenses and the lens holders.*



**Attention:** *To prevent lens contamination, use powder-free gloves when disassembling, inspecting, cleaning, or replacing parts within the flow cell or when removing or replacing the flow cell within its assembly.*

#### Required Materials

- TORX™ T10 screwdriver
- Small, flat-blade screwdriver
- Lens tissue or nonparticulating swab



- HPLC-grade methanol
- Belleville spring washer
- Flow cell gasket
- Powder-free gloves

## Procedure

To disassemble and clean the flow cell (and lenses):

1. Use the TORX T10 screwdriver to remove the three screws that secure one of the lens holder assemblies ([Figure 3-3](#)).

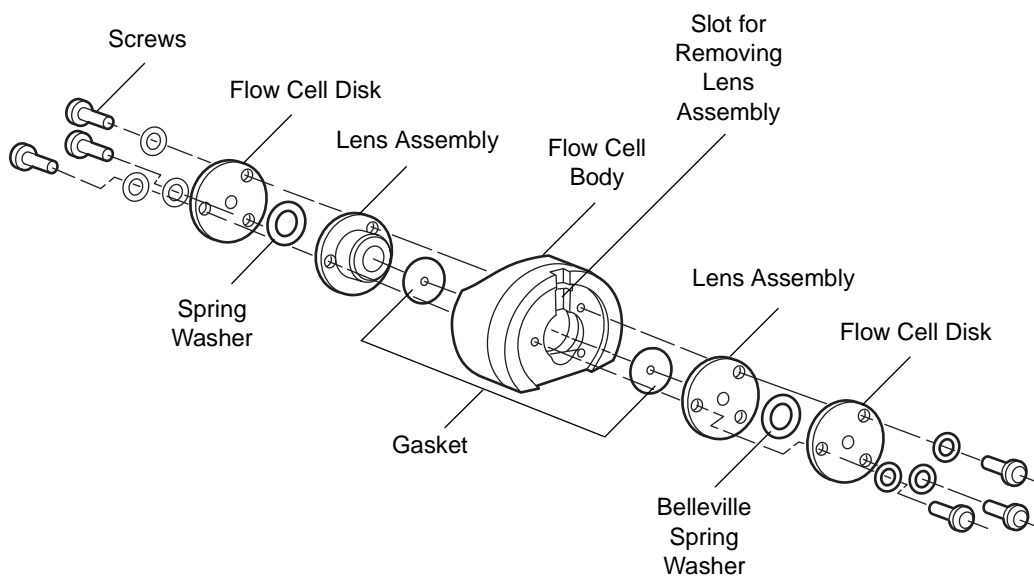

TP01464

Figure 3-3 Disassembling the Flow Cell

2. Use the small, flat-blade screwdriver to gently pry the lens assembly from the flow cell body at the slots.



**Attention:** Solvents other than methanol may damage a disassembled flow cell. In normal use, the gasket protects the lens holder from solvents.

3. Use a lens tissue or a nonparticulating swab to wipe the lens with methanol.

4. Remove and discard the gasket.
5. Repeat steps 1 through 4 to remove, disassemble, and clean the other lens holder assembly.
6. Use methanol and a nonparticulating swab to clean the flow cell body.

## Reassembling the Flow Cell

To reassemble the flow cell ([Figure 3-3](#)):

1. Insert a replacement gasket into one side of the flow cell body.
2. Align the screw holes of the lens assembly with the holes in the flow cell body.
3. Place the new Belleville spring washers (with the concave side facing out) onto the lens assembly.
4. Place the flow cell disk over the lens assembly.
5. Insert the three screws using the TORX T10 driver to gradually tighten each screw, alternating between the screws in a clockwise pattern. Tighten until the screws meet the flow cell disk, then tighten each screw 1/4-turn. If a torque screwdriver is available, tighten the screws to 16 in-oz (0.113 N-m).



**Attention:** Be careful not to overtighten the screws.

6. Check for leaks. If you find any leaks, repeat step 5.
7. Repeat steps 1 through 5 to reassemble the other side of the flow cell.

### 3.1.4 Installing the Flow Cell Assembly



**Attention:** The alignment of the flow cell in the optics bench is critical to detector operation. Be careful not to damage the flow cell body.

To install the flow cell assembly:

1. While you hold the flow cell assembly in a vertical orientation ([Figure 3-2](#)), insert the assembly into the optics bench. Note that the flow cell is self-aligning and uses the guide pins on the optics bench.
2. Gently push the front of the assembly until it seats on the front alignment pins.
3. Hand-tighten the thumbscrews.
4. Reconnect the fluidic lines.
5. Replace the front cover.
6. Flush the flow cell ([Section 3.1.1, Flushing the Flow Cell](#)).

## 3.2 Replacing the Lamp

---

Replace the lamp in the 2996 Detector when either of the following conditions exists:

- The sampling rate requires an excessively long exposure time (more than 100 milliseconds).
- Intensity is low enough that sensitivity is not sufficient for your method.

**Note:** *An improperly inserted flow cell could appear to be a problem with the lamp.*



**Caution:** *To avoid electrical hazards and exposure to UV light, turn off the power and disconnect the power cord before you begin this procedure.*



**Caution:** *The lamp and housing are extremely hot. To avoid the possibility of contacting hot surfaces, allow the lamp to cool for 15 minutes before you handle the lamp assembly or surfaces close to the lamp.*

**Note:** *If lamp intensity is low, but the lamp has not been used for 2000 hours, you may be able to increase lamp intensity by cleaning the flow cell ([Section 3.1, Flow Cell Maintenance](#)).*

Absorbance by the mobile phase also affects the apparent lamp intensity. For example, acetonitrile is more transparent than methanol at wavelengths less than 220 nm.



**Attention:** *Do not touch the lamp glass while unpacking or inserting the lamp. Touching lamp glass damages the lamp and reduces life expectancy.*



**Attention:** *To prevent lamp glass contamination, use powder-free gloves when removing or replacing the lamp.*



**Caution:** *The lamp may be very hot! Please allow it to cool for at least 15 minutes before you attempt to remove it.*

## Required Materials

- Slotted head screwdriver
- Powder-free gloves



**Caution:** To avoid electrical hazards when you perform the following procedure, power off the 2996 Detector and disconnect the power cord.

## Procedure

To replace the lamp:

1. Power off the 2996 Detector, disconnect the power cord, and allow the lamp to cool for at least 15 minutes.



**Caution:** To avoid the possibility of contacting hot surfaces, wait at least 15 minutes after powering off the detector before you handle the lamp.

2. Lift up the front panel cover and pull it away from the chassis.
3. Open lamp secure panel.

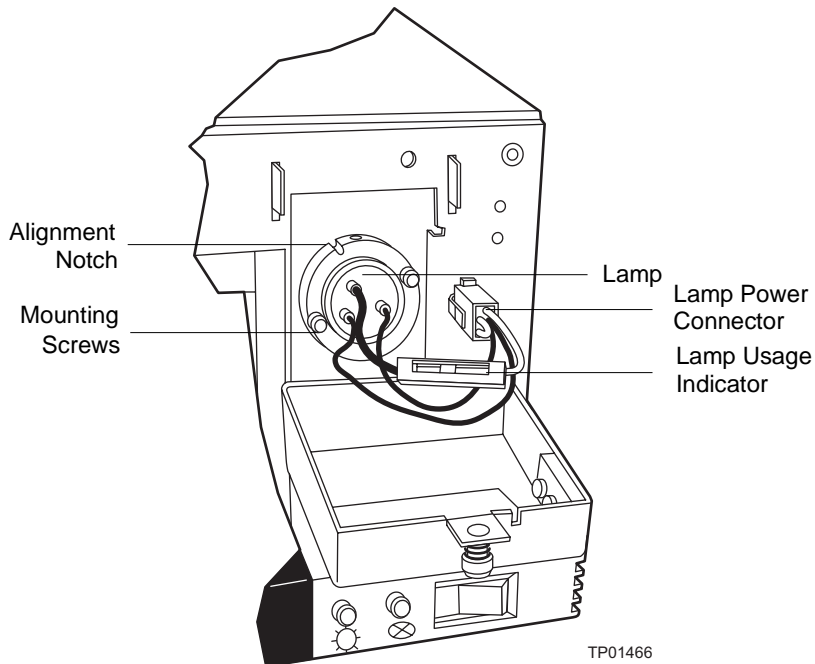

Figure 3-4 Lamp Power Connector and Mounting Screws

4. Use a slotted head screwdriver to unscrew the two mounting screws.
5. Grip the metal base of the lamp, pull the lamp out, and set it aside. Do not pull the wires to remove the lamp.
6. Carefully unpack the replacement lamp.
7. While wearing powder-free gloves and holding the lamp by its base, position the lamp so that the notch in the base aligns with the positioning pin in the optics bench.
8. Insert the lamp and secure it with the two screws. Make sure that the lamp base is flush against the lamp housing.
9. Reconnect the lamp power connector ([Figure 3-4](#)).
10. Secure the lamp access panel.
11. Install the front panel cover.
12. Reconnect the power cord and power on the 2996 Detector.

## 3.3 Replacing the Fuses

Replace the fuses under the conditions indicated in the troubleshooting table ([Section 2.1. Diagnostics](#)). The 2996 Detector requires two 2 A, 250 V fuses (5 mm × 20 mm).



**Caution:** To avoid electrical hazards, power off the 2996 Detector and disconnect the power cord before you perform the following procedure.

To replace the two fuses in the 2996 Detector:

1. Power off the 2996 Detector and remove the power cord.
2. Locate the fuse block below the power cord plug ([Figure 3-5](#)) on the rear panel.

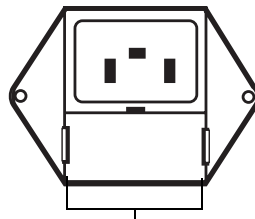

Squeeze Side Clips to  
Access Fuses

Figure 3-5 Fuse Block

3. Squeeze the two side clips on the fuse block while you pull out the block.

4. Remove the fuses from the block, then install the new fuses.
5. Position the fuse block with the small tab pointing down, then push in the block until the side clips engage.
6. Connect the power cord, then power on the 2996 Detector.

# Chapter 4

## Principles of the 2996 PDA Detector Optics

---

To use the Millennium<sup>32</sup> PDA software effectively, you must be familiar with the principles of operation of the optics and electronics of the Waters 2996 PDA Detector.

### 4.1 2996 Detector Optics

---

The 2996 Detector is an ultraviolet/visible light (UV/Vis) spectrophotometer with:

- 512 photodiodes
- Optical resolution of 1.2 nm per diode
- Operating wavelength range from 190 to 800 nm

The light path through the optics assembly of the 2996 Detector is shown in [Figure 4-1](#).

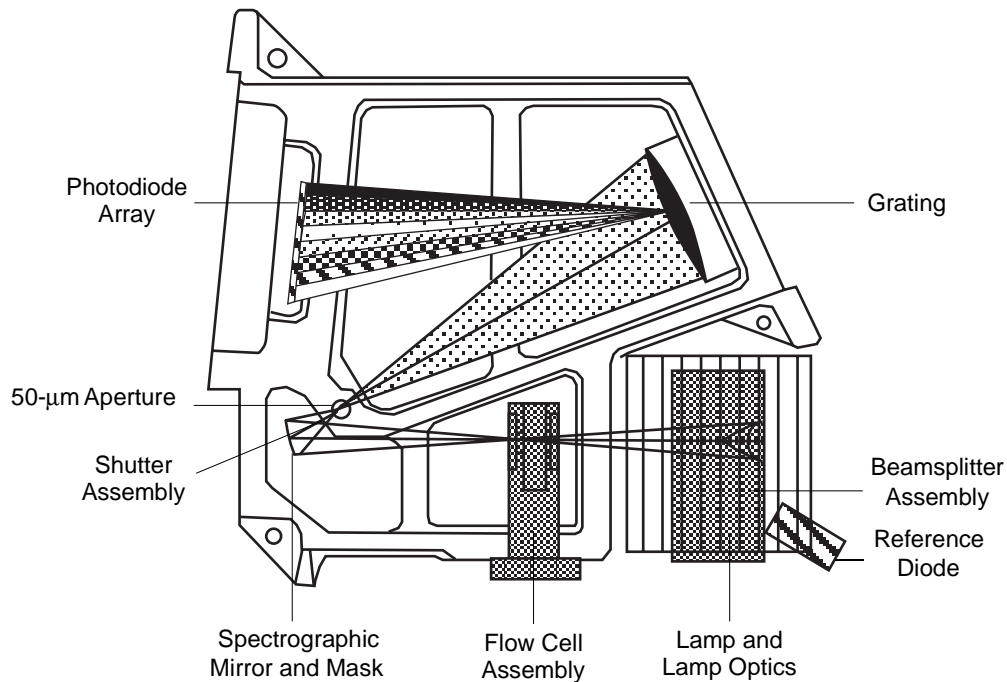

Figure 4-1 Optics Assembly Light Path

[Table 4-1](#) describes the optics assembly components in the 2996 Detector.

Table 4-1 Optics Assembly Components

Component	Function
Lamp and lamp optics	Focuses light from the deuterium source lamp via a mirror through a beamsplitter to the flow cell.
Beamsplitter and reference diode	Reflects part of the light back to a reference diode, which measures the intensity of the light emitted by the lamp. The detector uses this measurement to keep the lamp output constant.
Flow cell assembly	Houses the segment of the flow path (containing eluent and sample) through which the polychromatic light beam passes. This arrangement of optical components, with the flow cell positioned between the lamp and the grating, is commonly called reversed optics.



Table 4-1 Optics Assembly Components (*Continued*)

Component	Function
Spectrograph mirror and mask	The mirror focuses light transmitted through the flow cell onto the aperture at the entrance to the spectrographic portion of the optics. The mirror mask defines the beam of light focused on the spectrograph mirror.
Aperture	Controls wavelength resolution and intensity of light striking the photodiodes. The width of the aperture is 50 $\mu\text{m}$ .
Shutter assembly	Prevents light from reaching the photodiode array except during sampling and calibration. For details on the dark current, see <a href="#">Section 4.4.1, Calculating Absorbance</a> .
Grating	Disperses the light into bands of wavelengths and focuses those wavelength bands onto the plane of the photodiode array.
Second-order filter	Reduces the contribution of second-order reflection of UV light (less than 370 nm) to the light intensity observed at visible wavelengths (greater than 370 nm).
Photodiode array	An array of 512 photodiodes arranged linearly. The diode width and spacing provide a single wavelength resolution of 1.2 nm.

## 4.2 Resolving Spectral Data

The ability to distinguish similar spectra depends on photodiode spacing and the bandwidth of the light striking the photodiode. The bandwidth of the light striking the photodiodes depends on the aperture width.

The aperture width determines:

- Attainable wavelength bandwidth at the photodiode array
- Intensity of the light reaching the photodiode array (optical throughput)

The aperture creates a narrow beam that reflects from the grating to the photodiode array. The wavelength that strikes a particular diode depends on the angle of reflection from the grating.

[Figure 4-2](#) shows an absorbance spectrum of benzene obtained from the 2996 Detector using the 50- $\mu\text{m}$  aperture. In this spectrum, the wavelength resolution is sufficient to resolve five principal benzene absorption peaks.

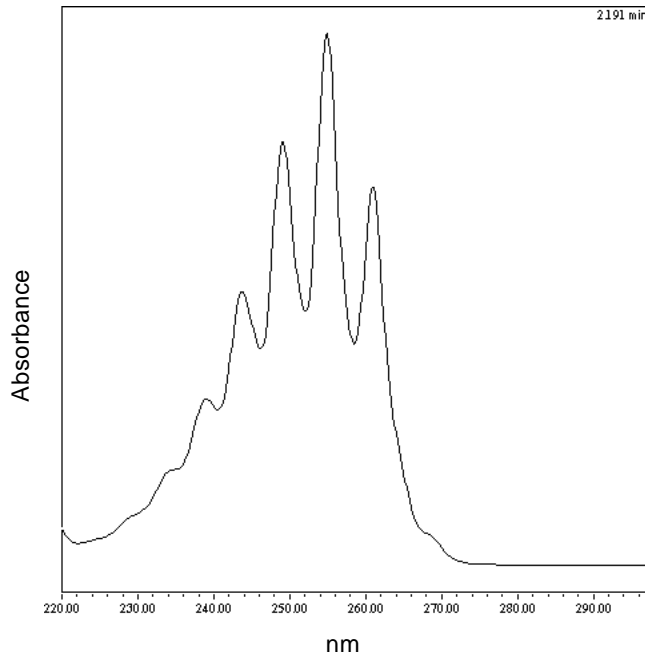

Figure 4-2 Benzene Spectrum at 1.2 nm Resolution

## 4.3 Measuring Light at the Photodiode

---

The 2996 Photodiode Array Detector measures the amount of light striking the photodiode array to determine the absorbance of the sample in the flow cell.

The array consists of 512 photodiodes arranged in a row. Each photodiode acts as a capacitor by holding a fixed amount of charge.

Light striking a photodiode discharges the diode ([Figure 4-3](#)). The magnitude of the discharge depends on the amount of light striking the photodiode.

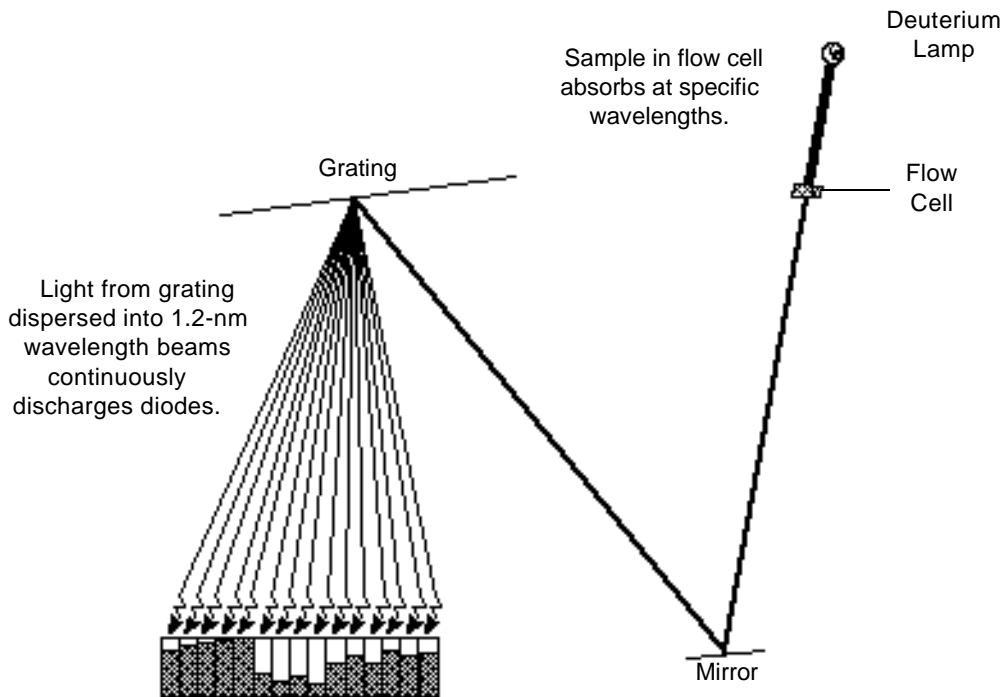

Figure 4-3 Photodiodes Discharged by Light

The 2996 Detector measures the amount of current required to recharge each photodiode. The current is proportional to the amount of light transmitted through the flow cell over the interval specified by the diode exposure time.

## Exposure Time

The 2996 Detector recharges each diode and reads the recharging current one diode at a time. The interval between two readings of an individual diode is the exposure time. The 2996 Detector requires less than 10 msec to sequentially read all of the diodes in the array and process the data. The minimum exposure time is 10 msec. You can set exposure time from 10 to 500 msec.

For example, if an exposure time is set to 50 milliseconds, the 2996 Detector:

1. Recharges diode 1 and reads the current required to recharge diode 1
2. Recharges diode 2 and reads the current required to recharge diode 2
3. Sequentially recharges and reads the current required to recharge all the remaining 510 photodiodes

4. Waits approximately 45 msec before beginning the recharge-and-reading sequence with diode 1 after all diodes have been recharged and read.

You set the exposure time parameter in the General tab of the 2996 PDA Instrument Method Editor. You can specify either Auto Exposure or Exposure Time. For details, refer to the *Millennium<sup>32</sup> Help*.

**Note:** For best signal-to-noise performance, adjust the wavelength range optimize autoexposure computations. For details, refer to the *Millennium<sup>32</sup> Help*.

## Using the Auto Exposure Parameter

The Auto Exposure time parameter allows the 2996 Detector optics to calculate the optimum exposure time needed to recharge the diodes based on lamp energy, lamp spectrum, mobile phase absorbance, and the chosen wavelength range using a single Deuterium light source from 190 to 800 nm. To minimize detector noise, Auto Exposure adjusts the exposure time from 50 to 90% of full scale.

The Auto Exposure time setting ensures that the photodiodes are:

- Not saturating due to overexposure
- Operating above the range of normal, dark current discharge

With auto exposure enabled, the 2996 Detector:

- Calculates exposure time at the start of a run based on maximum light intensity within the selected wavelength range
- Limits the exposure so that no diode within the given wavelength range discharges more than 90%
- Provides proper settings for signal-to-noise and dynamic range for each run

The Auto Exposure time setting may not support certain combinations of sampling rates, wavelength ranges, or filter time-constant settings required for your analysis. If this is the case, you can set the exposure time manually to adjust the exposure time from experiment to experiment.

## Using the Exposure Time Parameter

The Exposure Time parameter enables you to manually set the length of time the photodiodes are exposed to light before they are read. The supported range is 10 to 500 msec.

**Note:** Changing exposure times within a set of samples can cause changes in baseline noise.

Be aware that increasing the Exposure Time parameter has the potential to saturate the photodiodes. A longer exposure time may cause the 2996 Detector to lose the signal at certain wavelengths because of diode saturation. When specifying the Exposure Time, select a value that provides settings for an optimum signal-to-noise ratio over the wavelength range of your analysis (see the next topic "[Optimizing the Signal-to-Noise Ratio](#)").

## Optimizing the Signal-to-Noise Ratio

To optimize signal-to-noise ratios, choose an acquisition wavelength range that includes only the wavelengths of interest and over which the mobile phase absorbs minimally ([Appendix C, Mobile Phase Absorbance](#)). Setting the bandwidth to higher values can improve signal-to-noise ratios.

## 4.4 Computing Absorbance Data Points

---

The 2996 Detector calculates absorbance values before transmitting the data to the Millennium<sup>32</sup> database. To calculate absorbance, the 2996 Detector:

- Computes the absorbance at each diode using the dark current and reference spectrum ([Section 4.4.1, Calculating Absorbance](#))
- Averages the absorbances at a particular wavelength as specified in the spectra per second sample rate and reports the average as a single data point ([Section 4.4.2, Resolution](#))
- Can apply a filter ([Section 4.4.3, Filtering Data](#))

### 4.4.1 Calculating Absorbance

The detector computes absorbance by subtracting the dark current and reference spectrum from the acquired spectrum. Absorbance is based on the principles of Beer's Law.

## Beer's Law

The relationship between the quantity of light of a particular wavelength arriving at the photodiode and the concentration of the sample passing through the flow cell is described by the Beer-Lambert Law (commonly called Beer's Law). Beer's Law is expressed as

$$A = \epsilon lc$$

where:

$A$  = absorbance

$\epsilon$  = molar absorptivity

$l$  = path length (1.0 cm in the 2996 Detector normal flow cell)

$c$  = molar concentration

Beer's Law applies only to well-equilibrated dilute solutions. It assumes that the refractive index of the sample remains constant, that the light is monochromatic, and that no stray light reaches the detector element. As concentration increases, the chemical and instrumental requirements of Beer's law may be violated, resulting in a deviation from (absorbance versus concentration) linearity ([Figure 4-4](#)). The absorbance of mobile phase can reduce the linear range by the amounts shown in [Appendix C, Mobile Phase Absorbance](#).

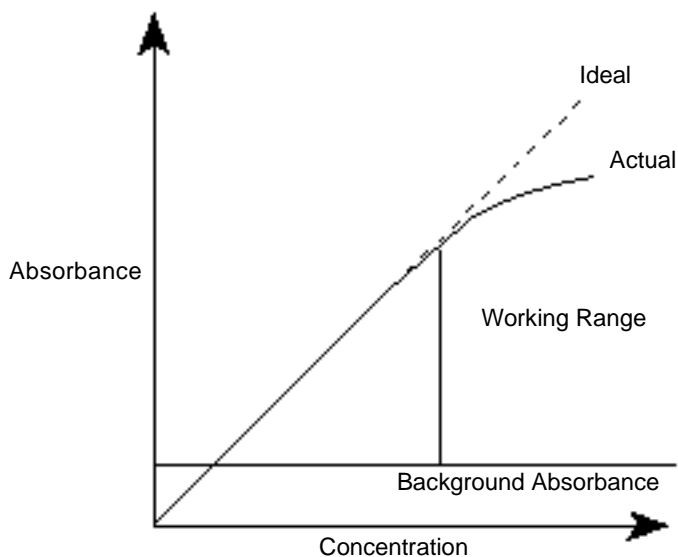

Figure 4-4 Absorbance as a Function of Concentration

## Dark Current

Photodiodes lose charge over time even when they are not exposed to light. The amount of charge lost is called *dark current*.

At the start of a chromatographic run, the 2996 Detector closes the shutter to take a dark current reading for each diode. The shutter closes after the exposure time is calculated and stays closed for the same interval as the exposure time.

The detector subtracts the dark current values from the current values recorded during absorbance measurements for both the sample and the reference spectra.

## Reference Spectrum

Immediately after the dark current measurement and before any components are eluted, the 2996 Detector records a reference spectrum. The reference spectrum is a measure of lamp intensity and mobile phase absorbance over the interval specified in the exposure time taken with the shutter open.

**Note:** For best results, the reference spectrum should be representative of the initial mobile phase.

**Note:** For extremely long exposure times, the dark current and reference spectrum readings may take several seconds to finish.

## Absorbance

The 2996 Detector calculates the absorbance for each diode at the end of each exposure time using the following equation:

$$Absorbance_n = \log \left[ \frac{(S_n - D_n)}{(R_n - D_n)} \right]$$

where:

*S* = obtained during sample analysis

*D* = obtained during the dark current test

*R* = obtained from the reference spectrum

*n* = diode number

## 4.4.2 Resolution

The data reported by the 2996 Detector to the Millennium<sup>32</sup> database can be the average of a number of data points. After calculating absorbance, the detector averages absorbance values based on:

- Spectral resolution
- Sample rate

### Averaging Spectral Data Based on Resolution

Spectral resolution (or bandwidth) is the wavelength interval (in nanometers) between data points in an acquired spectrum. The minimal resolution of the 2996 Detector is 1.2 nm. For example, in 3D mode, the 2996 Detector averages three adjacent diodes for each reported wavelength when the spectral resolution is set in the Millennium<sup>32</sup> software to 3.6 nm. In 2D mode, absorbance values are computed based on the bandwidth setting. 2D mode is supported in Millennium<sup>32</sup> software versions 4.0 or higher.

### Averaging Chromatographic Data Based On Sample Rate

Sample rate is the number of data points per second reported to the Millennium<sup>32</sup> database. The number of times the photodiodes are read during the sample rate interval is dependent on the exposure time. For example, if exposure time is 25 msec, and sample rate is 1 sec, then readings per data point are:

$$\frac{1000 \text{ msec}}{25 \text{ msec}} = 40$$

The readings are averaged and reported as a single data point.

### Combining Spectral Resolution and Sample Rate

Spectral resolution and sample rate have opposite effects on noise and spectral detail. Increasing the value of the spectral resolution parameter and decreasing the number of spectra per second decrease the size of the data file.

**Note:** The data storage rate is based on wavelength range, spectral resolution, and sample rate, which are set in the General tab of the 2996 PDA Instrument Method Editor. For details, refer to the Millennium<sup>32</sup> Help.

## 4.4.3 Filtering Data

Use the General tab of the 2996 PDA Instrument Method Editor (for details, refer to *Millennium<sup>32</sup> Help*) to apply an optional noise filter (the Filter Response parameter) to the data sent to the Millennium<sup>32</sup> software database. A noise filter of 1 second is the default value, which provides a good signal-to-noise ratio for most chromatographic separations.



Note the following with regard to filtering data:

- The noise filter is a digital (low pass) filter.
- The filter calculates a data point that is a modified rolling average for a wavelength over a number of readings.
- The filter values are comparable to the effects of a 0.1- to 3-second RC filter.

# Chapter 5

## Spectral Contrast Theory

---

This chapter explains the theory behind the Spectral Contrast technique, which is used to compare UV/Vis absorbance spectra collected by the 2996 Detector. Spectral Contrast makes use of the fact that different compounds have differently shaped absorbance spectra. This chapter describes how Spectral Contrast represents absorbance spectra as vectors. When applied to the UV/Vis absorbance data collected by the 2996 Detector, the Spectral Contrast technique determines whether differences between spectra are due to the presence of multiple compounds in the same peaks (coelution) or due to nonideal conditions such as noise, photometric error, or solvent effects.

### 5.1 Comparing Absorbance Spectra

---

The shape of an absorbance spectrum is determined by the relative absorbance at different wavelengths. The shape of a compound's absorbance spectrum is a characteristic of that compound at the solvent and pH conditions under which the absorbance spectrum is measured.

[Figure 5-1](#) shows the absorbance spectra for the two compounds, A and B. The ratio of the absorbance at 245 nm to the absorbance at 257 nm is approximately 2.2 for compound A and 0.7 for compound B.

The absorbance ratios of two wavelength pairs is a limited spectral comparison. For more information, you need to compare the absorbance ratios of multiple wavelength pairs.

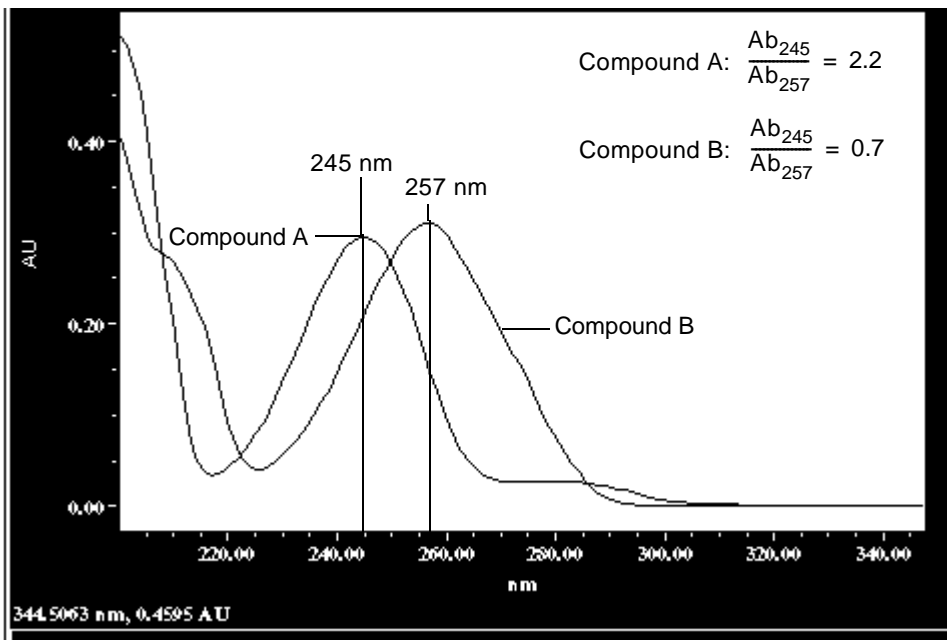

Figure 5-1 Comparing Spectra of Two Compounds

## 5.2 Representing Spectra as Vectors

The Spectral Contrast technique uses vectors to quantify differences in the shapes of spectra. Spectral Contrast converts baseline-corrected spectra to vectors and then compares the vectors. Spectral vectors have two properties:

- **Length** – Proportional to analyte concentration.
- **Direction** – Determined by the relative absorbance of the analyte at all wavelengths (its absorbance spectrum). Direction is independent of concentration for peaks that are less than 1.0 AU across the collected wavelength range.

Vector direction contributes to the identification of a compound, since the direction is a function of the absorbance spectrum of the compound. The ability of spectral vectors to differentiate compounds depends on the resolution of spectral features. As both wavelength range and spectral resolution increase, the precision of a spectral vector for the resultant spectrum increases. A vector derived from the 2996 PDA Detector can include absorbances in any range between 190 nm and 800 nm. To enhance spectral sensitivity, set the bench resolution to 1.2 nm.

## 5.2.1 Vectors Derived from Two Wavelengths

The Spectral Contrast algorithm uses vectors to characterize spectra ([Figure 5-2](#)). To understand the vector principle, consider two vectors ([Figure 5-2](#)) based on the spectra depicted in [Figure 5-1](#).

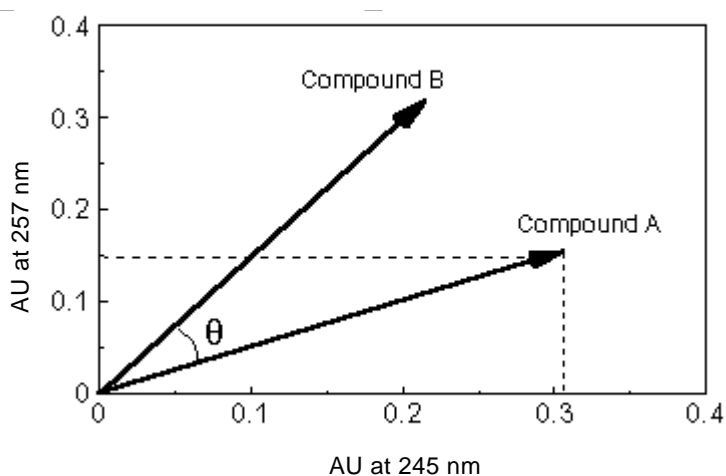

Figure 5-2 Plotting Vectors for Two Spectra

The axes in [Figure 5-2](#) are in absorbance units at the two wavelengths used to calculate the absorbance ratio shown in [Figure 5-1](#). The head of the vector for Compound A is at the intersection of the absorbance values (for Compound A) at the two wavelengths represented by each axis. The other vector is similarly derived for the spectrum of Compound B.

The vector for Compound B points in a direction different from that of the vector for Compound A. The difference in direction, which reflects the difference in the absorbance ratios of the two compounds at wavelengths 245 nm and 257 nm, is called the Spectral Contrast angle. A Spectral Contrast angle (e.g.,  $\theta$  in [Figure 5-2](#)) greater than zero indicates a shape difference between spectra ([Section 5.3, Spectral Contrast Angles](#)). The length of the vector is proportional to the concentration.

## 5.2.2 Vectors Derived from Multiple Wavelengths

When absorbance ratios are limited to two wavelengths, the chance that two different spectra will have the same absorbance ratio is much greater than if comparison is made using absorbance ratios at many wavelengths. Therefore, the Spectral Contrast technique uses absorbances from multiple wavelengths to form a vector in an  $n$ -dimensional vector space, where  $n$  is the number of wavelengths from the spectrum.

To compare two spectra, the Spectral Contrast technique forms a vector for each spectrum in an  $n$ -dimensional space. The two spectral vectors are compared mathematically to compute the angle between the two vectors.

Just as in the two-wavelength comparison, a Spectral Contrast angle of zero in  $n$ -dimensional space means that all ratios of absorbances at corresponding wavelengths match. Conversely, if any comparison of ratios does not match, the corresponding vectors point in different directions.

## 5.3 Spectral Contrast Angles

---

Spectra that have the same shape have vectors that point in the same direction. Spectra that have different shapes have vectors that point in different directions. The angle between the two vectors of any two spectra, the Spectral Contrast angle, quantifies the magnitude of the shape difference between the spectra. The *Spectral Contrast angle* is the difference in direction between the spectral vectors of two spectra.

A Spectral Contrast angle can vary from  $0^\circ$  to  $90^\circ$ . A Spectral Contrast angle near  $0^\circ$  indicates little shape difference between the compared spectra. Matching a spectrum to itself produces a Spectral Contrast angle of exactly  $0^\circ$ . The maximum Spectral Contrast angle,  $90^\circ$ , indicates that the two spectra do not overlap at any wavelength.

To illustrate the relationship between Spectral Contrast angle and spectral shape differences, consider the pairs of spectra shown in [Figure 5-3](#), [Figure 5-4](#), and [Figure 5-5](#).

### Spectra with Different Shapes

In [Figure 5-3](#), the absorbance spectra of two compounds, A and B, are distinctly different, and therefore, have a large Spectral Contrast angle.

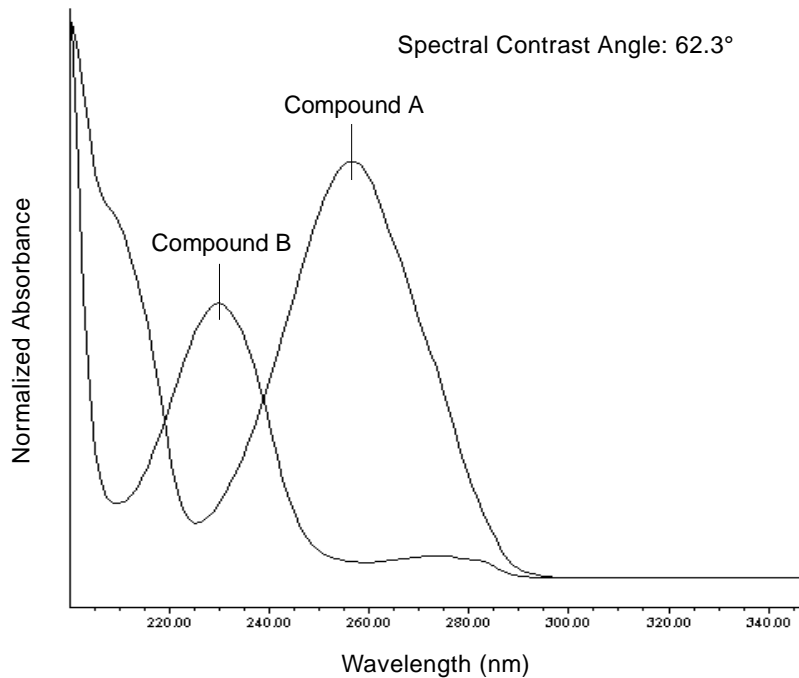

Figure 5-3 Spectra with a Large Spectral Contrast Angle

### Spectra with Similar Shapes

In [Figure 5-4](#), the absorbance spectra of two compounds, A and B, are similar, and therefore, have a small Spectral Contrast angle ( $3.0^\circ$ ).

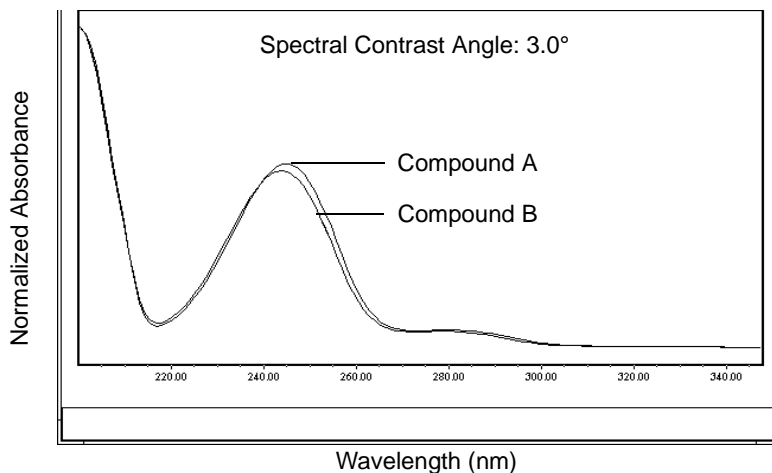

Figure 5-4 Spectra with a Small Spectral Contrast Angle

### Differences Between Spectra of the Same Compound

Small but significant differences between absorbance spectra can occur because of factors other than those due to the absorbance properties of different compounds. For example, multiple spectra of the *same* compound may exhibit slight differences because of detector noise, photometric error, high sample concentration, or variations in solvent conditions. The spectra in [Figure 5-5](#), for example, show how instrument noise can affect the shape of an absorbance spectrum of one compound. This effect is most likely to occur at low concentrations where the signal-to-noise ratio is low. Note that the Spectral Contrast angle between these absorbance spectra of the same compound is  $3.4^\circ$ .

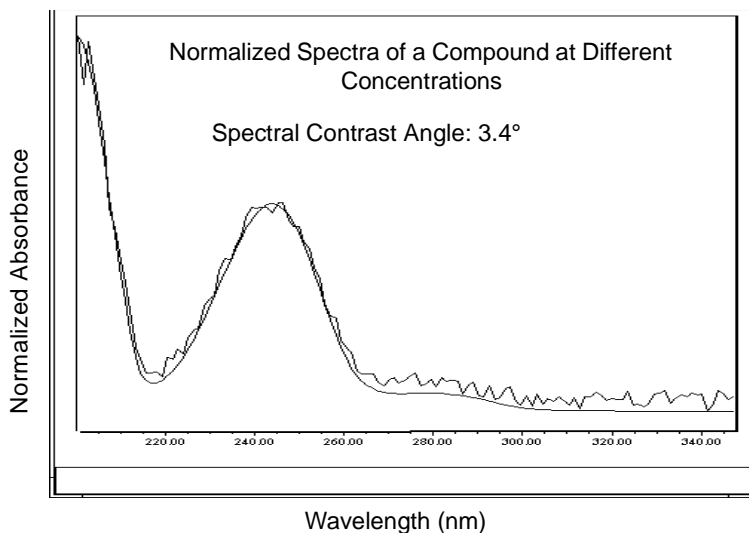

Figure 5-5 Absorbance Spectra of a Compound at Two Concentrations

## 5.4 Undesirable Effects

Shape differences between absorbance spectra can be caused by one or more of the following undesirable effects:

- Detector noise
- Photometric error caused by high sample concentration
- Variation in solvent composition

These sources of spectral variation can cause chemically pure, baseline-resolved peaks to exhibit a small level of spectral inhomogeneity. You can assess the significance of spectral inhomogeneity by comparing a Spectral Contrast angle to a Threshold angle (Section 5.4.4).

### 5.4.1 Detector Noise

Statistical and thermal variations add electrical noise to the absorbance measurements made by the 2996 Detector. The noise manifests itself as fluctuations in the baseline, known as *baseline noise*. The magnitude of any absorbance differences caused by statistical and thermal variations can be predicted from the instrument noise in the baseline region of a chromatogram.



## 5.4.2 Photometric Error

At high absorbances (generally greater than 1 AU), a combination of effects can produce slight departures (about 1%) from Beer's Law due to photometric error. Although photometric errors at this level may have a negligible effect on quantitation, they can be a significant source of spectral inhomogeneity. To minimize the effects of photometric error for all Spectral Contrast operations, the maximum spectral absorbance of a compound should be less than 1 AU. Keep in mind that the absorbance of the mobile phase reduces the working linear dynamic range by the amount of mobile phase absorbance at each wavelength. For examples of mobile phase absorbance, see [Appendix C, Mobile Phase Absorbance](#).

**Note:** For more information about the effects of the photometric error curve, refer to *Principles of Instrumental Analysis, third edition, by Douglas A. Skoog, Saunders College Publishing, 1985, pp 168–172.*

## 5.4.3 Solvent Changes

As long as solvent concentration and composition do not change (isocratic operation), the background absorbance, if any, by the solvent remains constant. A change, however, in solvent pH or composition, such as occurs in gradient operation, can affect the intrinsic spectral shape of a compound, as shown in [Figure 5-6](#).

## 5.4.4 Threshold Angle

In addition to computing Spectral Contrast angles, the Spectral Contrast technique also computes a Threshold angle. The Threshold angle is the maximum Spectral Contrast angle between spectra that can be attributed to nonideal phenomena.

Comparison of a Spectral Contrast angle to its Threshold angle can assist in determining if the shape difference between spectra is genuine, that is, generated by mixtures that are dissimilar. In general, a Spectral Contrast angle less than its Threshold angle indicates that shape differences can be attributed to nonideal phenomena alone, and that there is no evidence for genuine differences between the spectra. A Spectral Contrast angle greater than its Threshold angle indicates that the shape differences are due to genuine differences between the spectra. When automating the spectra contrast comparison, the maximum absorbance of the spectra must not exceed 1 AU.

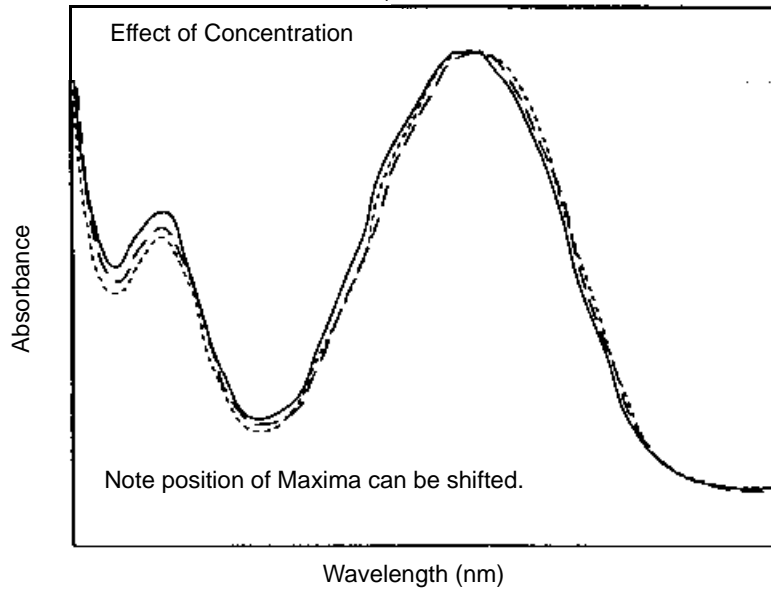
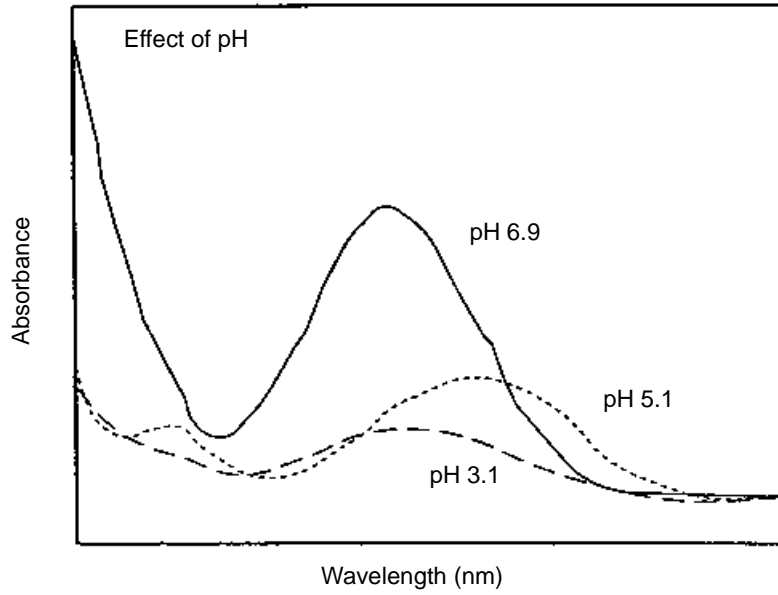

Figure 5-6 Effects of pH and Solvent Concentration on the Absorbance Spectrum of *p*-Aminobenzoic Acid

# Appendix A

## Detector Specifications

[Table A-1](#) lists the 2996 PDA Detector specifications.

Table A-1 2996 Detector Specifications

Item	Specification
Dimensions	Width: 11.5 in. (29 cm) Depth: 24 in. (61 cm) Height: 8.125 in. (22 cm)
Weight	31.5 lbs (14.3 kg)
Wavelength range	190 to 800 nm
Wavelength accuracy	±1 nm
Linearity range*	5% at 2.0 AU, propylparaben, at 256 nm
Spectral resolution	1.2 nm
Baseline noise	±1.5 × 10 <sup>-5</sup> AU peak-to-peak, dry, at 254 nm
Drift	1 × 10 <sup>-3</sup> AU/hour at 254 nm (after warmup) ΔT ≤ 1°C per hour
Flow cells	Pathlength (mm): Tubing (ID):
Standard	10 0.009 in.
Semi-preparative	3 0.040 in.
Variable path flow cell	0.15 - 3 0.004 in.
Microbore	3 0.005 in.
Inert	10 0.010 in.
Autopurification	0.5 0.009 in. (A Inlet) 0.020 in. (P Inlet) 0.040 in. (Common Outlet)

\*. Per ASTM 685-79

# Appendix B

## Spare Parts

---

The spare parts listed in [Table B-1](#) are recommended for customer installation. Damage incurred by performing unauthorized work on your 2996 Detector may invalidate certain warranties.

Table B-1 Spare Parts

Item	Part Number
Flow cell, standard	WAT057919
Flow cell, semi-preparative	WAT057463
Flow cell, microbore	WAT057462
Flow cell, inert	WAT057461
Flow cell, Autopurification	289000612
Variable pathlength flow cell	WAT057664
Gasket, flow cell (2)	WAT057924
Belleville washer (2)	WAT057925
Lens mount and lens (2)	WAT057923
Semi-prep lens kit	WAT057968
Deuterium lamp	WAT052586 (PM Kit)
Fuse, fast 4A, 250 V (5 × 20 mm)	WAT057337
Waters <sup>®</sup> Erbium Perchlorate Wavelength Accuracy Solution	WAT042885
Waters Absorbance Detector Linearity Solution	WAT042881



# Appendix C

## Mobile Phase Absorbance

This appendix lists the absorbances at several wavelengths for commonly used mobile phases. Choose your mobile phase carefully to reduce baseline noise.

The best mobile phase for your application is one that is transparent at the chosen detection wavelengths. Such a mobile phase ensures that any absorbance is due only to the sample. Absorbance by the mobile phase also reduces the linear dynamic range of the detector by the amount of absorbance that is autozeroed out. Wavelength, pH, and concentration of the mobile phase will affect its absorbance. Examples of several mobile phases are provided in [Appendix C-1](#).

Table C-1 Mobile Phase Absorbance Measured Against Air or Water

	Absorbance at Specified Wavelength (nm)									
	200	205	210	215	220	230	240	250	260	280
<b>Solvents</b>										
Acetonitrile	0.05	0.03	0.02	0.01	0.01	<0.01	—	—	—	—
Methanol (not degassed)	2.06	1.00	0.53	0.37	0.24	0.11	0.05	0.02	<0.01	—
Methanol (degassed)	1.91	0.76	0.35	0.21	0.15	0.06	0.02	<0.01	—	—
Isopropanol	1.80	0.68	0.34	0.24	0.19	0.08	0.04	0.03	0.02	0.02
Unstabilized Tetrahydrofuran (THF, fresh)	2.44	2.57	2.31	1.80	1.54	0.94	0.42	0.21	0.09	0.05
Unstabilized Tetrahydrofuran (THF, old)	>2.5	>2.5	>2.5	>2.5	>2.5	>2.5	>2.5	>2.5	2.5	1.45
<b>Acids and Bases</b>										

Table C-1 Mobile Phase Absorbance Measured Against Air or Water (Continued)

	Absorbance at Specified Wavelength (nm)									
	200	205	210	215	220	230	240	250	260	280
Acetic acid, 1%	2.61	2.63	2.61	2.43	2.17	0.87	0.14	0.01	<0.01	—
Hydrochloric acid, 0.1%	0.11	0.02	<0.01	—	—	—	—	—	—	—
Phosphoric acid, 0.1%	<0.01	—	—	—	—	—	—	—	—	—
Trifluoroacetic acid	1.20	0.78	0.54	0.34	0.22	0.06	<0.02	<0.01	—	—
Diammonium phosphate, 50 mM	1.85	0.67	0.15	0.02	<0.01	—	—	—	—	—
Triethylamine, 1%	2.33	2.42	2.50	2.45	2.37	1.96	0.50	0.12	0.04	<0.01
<b>Buffers and Salts</b>										
Ammonium acetate, 10 mM	1.88	0.94	0.53	0.29	0.15	0.02	<0.01	—	—	—
Ammonium bicarbonate, 10 mM	0.41	0.10	0.01	<0.01	—	—	—	—	—	—
EDTA, disodium, 1 mM	0.11	0.07	0.06	0.04	0.03	0.03	0.02	0.02	0.02	0.02
HEPES, 10 mM, pH 7.6	2.45	2.50	2.37	2.08	1.50	0.29	0.03	<0.01	—	—
MES, 10 mM, pH 6.0	2.42	2.38	1.89	0.90	0.45	0.06	<0.01	—	—	—

Table C-1 Mobile Phase Absorbance Measured Against Air or Water (Continued)

	Absorbance at Specified Wavelength (nm)									
	200	205	210	215	220	230	240	250	260	280
Potassium phosphate, monobasic (KH <sub>2</sub> PO <sub>4</sub> ), 10 mM	0.03	<0.01	—	—	—	—	—	—	—	—
Potassium phosphate, dibasic, (K <sub>2</sub> HPO <sub>4</sub> ), 10 mM	0.53	0.16	0.05	0.01	<0.01	—	—	—	—	—
Sodium acetate, 10 mM	1.85	0.96	0.52	0.30	0.15	0.03	<0.01	—	—	—
Sodium chloride, 1 M	2.00	1.67	0.40	0.10	<0.01	—	—	—	—	—
Sodium citrate, 10 mM	2.48	2.84	2.31	2.02	1.49	0.54	0.12	0.03	0.02	0.01
Sodium formate, 10 mM	1.00	0.73	0.53	0.33	0.20	0.03	<0.01	—	—	—
Sodium phosphate, 100 mM, pH 6.8	1.99	0.75	0.19	0.06	0.02	0.01	0.01	0.01	0.01	<0.01
Tris HCl, 20 mM, pH 7.0	1.40	0.77	0.28	0.10	0.04	<0.01	—	—	—	—
Tris HCl, 20 mM, pH 8.0	1.80	1.90	1.11	0.43	0.13	<0.01	—	—	—	—
<b>Waters PIC<sup>®</sup> Reagents</b>										
PIC A, 1 vial/L	0.67	0.29	0.13	0.05	0.03	0.02	0.02	0.02	0.02	<0.01
PIC B6, 1 vial/L	2.46	2.50	2.42	2.25	1.83	0.63	0.07	<0.01	—	—

Table C-1 Mobile Phase Absorbance Measured Against Air or Water (Continued)

	Absorbance at Specified Wavelength (nm)									
	200	205	210	215	220	230	240	250	260	280
PIC B6, low UV, 1 vial/L	0.01	<0.01	—	—	—	—	—	—	—	—
PIC D4, 1 vial/L	0.03	0.03	0.03	0.03	0.02	0.02	0.02	0.02	0.02	0.01
<b>Detergents</b>										
BRIJ 35, 1%	0.06	0.03	0.02	0.02	0.02	0.01	<0.01	—	—	—
CHAPS, 0.1%	2.40	2.32	1.48	0.80	0.40	0.08	0.04	0.02	0.02	0.01
SDS, 0.1%	0.02	0.01	<0.01	—	—	—	—	—	—	—
Triton <sup>®</sup> X-100, 0.1%	2.48	2.50	2.43	2.42	2.37	2.37	0.50	0.25	0.67	1.42
Tween <sup>™</sup> 20, 0.1%	0.21	0.14	0.11	0.10	0.09	0.06	0.05	0.04	0.04	0.03





# Index

## A

- Absorbance
  - maximum [65](#)
  - mobile phase [69](#)
  - photometric error [65](#)
  - solvent change effects [65](#)
  - Waters 2996 calculations [53](#), [55](#)
- Acquisition
  - Auto Exposure parameter [52](#)
  - Exposure Time parameter [52](#)
- Analog output specifications [25](#), [26](#)
- Aperture width [49](#)
- Auto Exposure parameter [52](#)

## B

- Beer's law [54](#), [65](#)

## C

- Calibration [36](#)
- Column, connecting [29](#)
- Compression fittings [29](#)
- Connections
  - column [29](#)
  - events [27](#)
  - fluidic [29](#)
  - non-IEEE-488 [25](#)
  - rear panel [22](#)
  - terminal strip [27](#)
- Contact closures [25](#)
- Contacting Waters Technical Service [33](#), [35](#)
- Conventions, documentation [17](#)

## D

- Dark current [55](#)

- Data acquisition
  - Auto Exposure parameter [52](#)
  - Exposure Time parameter [52](#)
- Derived vectors [60](#)
- Diagnostics [35](#)
- Documentation conventions [17](#)

## E

- Electrical connections [21](#)
- Events
  - connections [25](#), [27](#)
  - electrical specifications [28](#)
  - terminal strip connections [26](#)
- Exposure Time parameter [52](#)

## F

- Fittings [29](#)
- Flow cell
  - cleaning [41](#)
  - exploded view [41](#)
  - flushing [37](#)
  - maintenance [37](#)
  - removing [38](#)
- Fluid
  - connecting lines [29](#)
  - fittings [29](#)
- Fuses
  - IEC-rated [21](#)
  - maintenance [45](#)
  - replacement [45](#)

## I

- IEC-rated fuses [21](#)
- Inputs [25](#), [27](#), [28](#)
- Installation

electrical [21](#)  
 fluidic [29](#)  
 site selection [20](#)

#### Instrument method

Auto Exposure parameter [52](#)  
 Exposure Time parameter [52](#)

## L

#### Lamp

hardware theory [48](#)  
 replacement [43](#), [44](#)

## M

#### Maintenance

flow cell [37](#)  
 fuse [45](#)  
 lamp [43](#)  
 PDA detector [37–46](#)

Match Angle, photometric error effects [65](#)

Maximum absorbance [65](#)

Millennium Chromatography Manager,  
 connections [22](#)

#### Mobile phase

absorbances [69](#)  
 wavelengths [69](#)

## N

Noise effects [64](#)

Nonidealities [64](#)

Non-IEEE-488 connections [25](#)

## O

Outputs [25](#), [27](#), [28](#)

## P

Parts, spare [68](#)

Photodiode array [50](#)

Photometric error [65](#)

Power connections [21](#)

Purity Angle, photometric error effects [65](#)

## R

Rear panel connections [22](#)

Reference spectrum [55](#)

## S

Shutdown, procedure [32](#)

Solvent Angle, photometric error effects [65](#)

Solvent changes [65](#)

Spare parts [68](#)

#### Specifications

analog output [25](#), [26](#)

event inputs [28](#)

event outputs [28](#)

Waters 2996 [67](#)

#### Spectra

derived vectors [60](#)

spectral shape differences [64](#)

vectors [59](#)

#### Spectral Contrast

derived vectors [60](#)

spectral shape differences [64](#)

theory [58–66](#)

vectors [59](#)

Spectral resolution [49](#)

Spectrum match, spectral shape differences  
[64](#)

Start up, procedure [30](#)

## T

Terminal strip

connections [26](#), [27](#)  
diagram [27](#)  
Threshold angle [64](#)  
Troubleshooting [33–36](#)  
Tubing, cutting [29](#)

## U

Undesirable effects, shape differences [64](#)

## V

Vectors

derived from multiple wavelengths [60](#)  
derived from two wavelengths [60](#)  
spectra, representing [59](#)  
spectral contrast [59](#)

## W

Waters 2996

absorbance calculations [53](#), [55](#)  
aperture width [49](#)  
dark current [55](#)  
detector optics, overview [47–49](#)  
hardware theory [47–57](#)  
photodiode array overview [50](#)  
reference spectrum [55](#)  
spare parts [68](#)  
specifications [67](#)  
spectral resolution [49](#)

Waters Technical Service, contacting [33](#), [35](#)

Wavelength

accuracy [36](#)  
derived vectors [60](#)  
mobile phase absorbances [69](#)