

Conditioning for several days was necessary to obtain chromatograms comparable to those obtained with the heated materials only a few hours after installation. Typical chromatograms from the unheated materials are shown in Figure 1 (A, B, C), Figure 2 (G, H), and Figure 3 (L, M).

Column materials that were not heated before packing (Table I: Columns 1-8, 10, 12, 14, 16) did not separate Dieldrin from *o,p'*-DDT or Malathion from Parathion. Partial degradation of *p,p'*-DDT and Methoxychlor was continuously observed; satisfactory recoveries of these compounds were obtained only after lengthy conditioning of the columns. The use of different sizes of solid support and proportions of the coating material did not improve column performance; the 80 to 100-mesh support was preferred because it could be tightly packed into a glass column.

The columns made of silanized Chromosorb W coated with SE-30 and QF-1 (Table I: Columns 17, 18) gave unsatisfactory resolution of some organochlorine and organophosphorus pesticides. Malathion retention time was greatly decreased as compared to those of Parathion and Carbophenothion; the multiple peaks produced indicated breakdown.

Although columns made of Chromosorb G coated with SE-30 and QF-1 (Table I: Columns 19, 20, 12, 22) gave good resolution of the test compounds, the recoveries based on peak heights were very low when compared to those from Chromosorb W columns. The *p,p'*-DDT breakdown was negligible. Heating of silicone-coated Chromosorb G in an oven at about 250 °C for 1.5 hours did not improve the recovery of pesticides.

In separating organochlorine and organophosphorus pesticides, Chromosorb W coated with DC-200 and QF-1 (20:0.8:1.2 grams) and heated at 230 °C for 2 hours before packing was comparable to that coated with SE-30 and QF-1.

ACKNOWLEDGMENT

We thank E. Coffin and S. W. Gunner of this Directorate for criticism of the manuscript.

RECEIVED for review May 28, 1968. Accepted August 7, 1968.

Calibration of the Methanol and Glycol Nuclear Magnetic Resonance Thermometers with a Static Thermistor Probe

Anthony L. Van Geet

Department of Chemistry, State University of New York, Buffalo, N. Y. 14214

IN NUCLEAR magnetic resonance, the temperature of a sample is commonly obtained by measuring the chemical shift of methanol or of 1,2-ethanediol (glycol). During our work with proton exchange (1) most of the experimental error was attributed to the temperature measurement, and a more accurate and direct method was desired.

A thermistor probe [U. S. Patent applied for (Figure 1)] fitting inside a 5-mm sample tube was built. A probe holder [Patent applied for (Figure 2)] conveniently holds the probe in place, and the probe does not touch the walls of the sample tube. Thus, the tube can spin freely around the stationary probe. The lower part of the probe is made from tubing of polyperfluoroethylene to provide thermal insulation. A resistance bridge and meter (Atkins 3F01A-C/AB/AC/AD/AE, Atkins Technical, P. O. Box 14405, University of Florida Station, Gainesville, Fla. 32603) provides a direct temperature reading spread out over 4 scale ranges. The meter may be placed as far from the probe as desired. The accuracy is ± 1 °C or better between -50 and +150 °C, and the reproducibility is 0.2 °C.

An alternate way to support the probe is shown in Figure 3. A sleeve bearing of polyperfluoroethylene permits the sample tube to spin while the probe rests on it. It is desirable to reinforce the rim of the thin glass sample tube with a compression ring, made by perforating the top of a pressure cap.

To prevent lifting of the sample by the nitrogen flow, a cylindrical polyperfluoroethylene spinning weight of 38 grams is used (2, 3).

The thermistor contains oxides of the transition metals,

and is paramagnetic. It affects the field homogeneity whenever it is in contact with the liquid, and retuning of the Y-fine homogeneity control is necessary when the probe is raised or lowered. With the thermistor 20 mm above the receiver coil, the observed line width is 1.6 Hz.

A temperature gradient occurs in the spinning sample tube. In a spinning methanol sample at -40 °C, the lowest temperature occurs at the bottom. The temperature was measured 10 and 30 mm above the bottom, and the difference was 1.0 °C. Without spinning, the difference is slightly larger. The first position coincides with the center of the receiver coil. The spectrometer is a Varian A60, with a V6031 probe and a V6040 temperature controller.

The stationary temperature at the coil changes slightly when the probe is inserted into the liquid, because heat leaks through it. The effect was studied at -40 °C from the chemical shift of methanol. Insertion of the probe raises the final temperature at the coil by 1.0 °C, irrespective of the depth of insertion. For a probe which had a thinner tip by omitting Part 4 of Figure 1, the effect of insertion was only 0.7 °C, but it was more difficult to keep the tip straight, and this probe had no other advantage.

For optimum accuracy of the temperature measurement, the probe is in contact with the liquid while taking the spectrum, then lowered to the position of the receiver coil to measure the temperature. On the other hand, for optimum resolution, the probe is raised above the surface of the liquid while taking the spectrum.

It is necessary to keep the polyperfluoroethylene tip of the probe straight to avoid interference with the spinning. A slight curvature is easily straightened out manually by bending in the opposite direction. The tip is protected when not in use. It is inert to all solvents and dilute acids and bases.

(1) A. L. Van Geet, *Inorg. Chem.*, **7**, 2026 (1968).
(2) A. L. Van Geet, *ANAL. CHEM.*, **40**, 1914 (1968).
(3) A. L. Van Geet, *Rev. Sci. Instrum.*, in press.

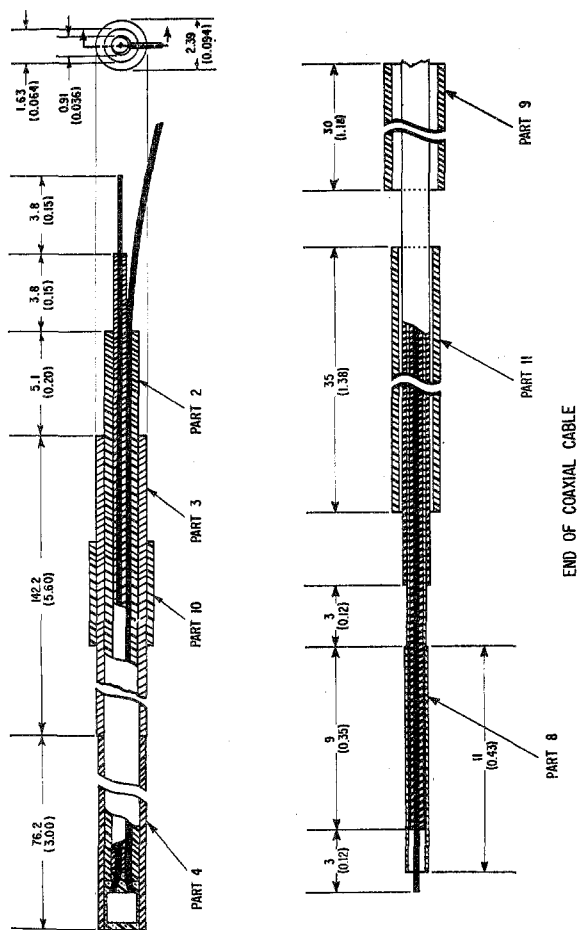

Figure 1. Static thermistor probe

Parts 8, 9, 11 are tubes of polyperfluoroethylene, and are used to connect the probe (left) to the coaxial cable (right). Part 3 is a brass tube (different cross-hatching). Part 10 is an adjustable stop to limit the depth of insertion

A spinning thermistor probe has also been built (3). This probe spins along with the sample tube, and the tube remains closed with a pressure cap.

CHEMICAL SHIFT OF METHANOL AND ETHYLENE GLYCOL

The chemical shift $\Delta\nu$ (in Hz) between the CH_2 and the OH group of methanol cannot be represented by a straight line over the entire temperature range of 220–330 °K. A quadratic equation fits the data with an error (RMS) of 0.6 °K (convenient graphs are available from the author).

$$T = 435.5 - 1.193 |\Delta\nu| - 29.3 (10^{-2}\Delta\nu)^2 \quad (1)$$

The coefficient of the quadratic term is small, and over a temperature range of 60 °K, the data can be fitted to a straight line with errors of 0.8 and 0.4 °K, respectively:

$$220\text{--}280 \text{ °K: } T = 478.6 - 1.906 |\Delta\nu| \quad (2)$$

$$260\text{--}320 \text{ °K: } T = 464.0 - 1.775 |\Delta\nu| \quad (3)$$

At the limits of these ranges, the straight line approximations still agree with Equation 1 within 0.6 °K.

The chemical shift between the CH_2 and OH groups of glycol fits a straight line perfectly with an error of 0.3 °K over the range 310–410 °K:

$$T = 466.0 - 1.694 |\Delta\nu| \quad (4)$$

At room temperature, these results agree with the calibration charts supplied by Varian Associates within 1 °K. At

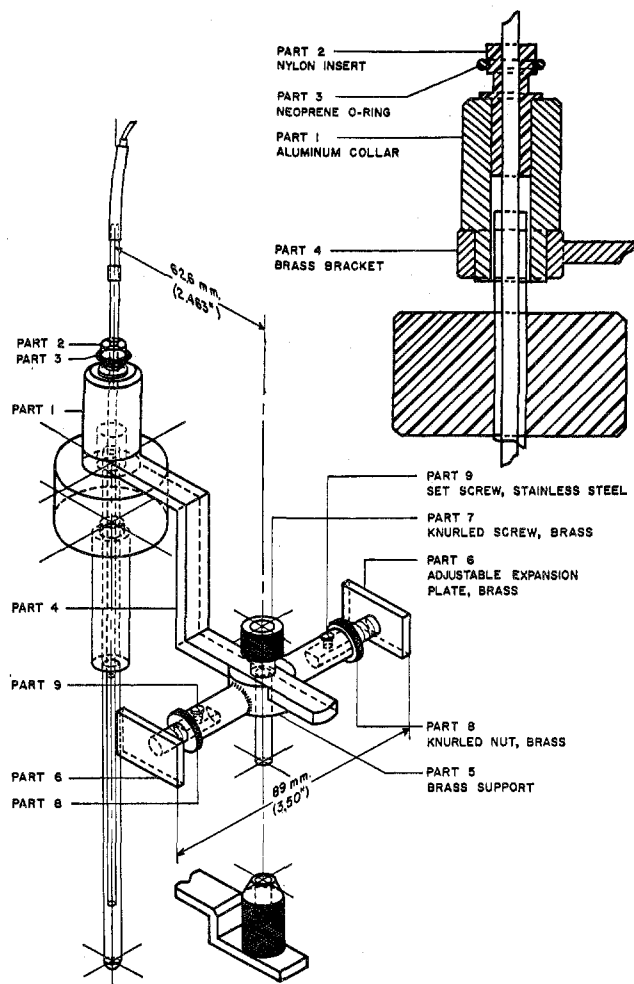

Figure 2. Clamp for static thermistor probe

Thermistor probe is supported by nylon insert 2 of aluminum collar 1, and does not touch the glass sample tube. The sample tube fits inside the cavity of collar 1 without touching it. The lower part of brass support 5 fits accurately inside the center hole of the vertical-position knurled nut (bottom) of the Varian NMR probe. The adjustable expansion plates 6 press against the faces of the magnet coils, and hold the clamp in place

220 °K, the Varian chart gives a temperature 4.2 °K lower, and at 410 °K, it gives 3.4 °K lower.

The results are probably accurate within 1 °K, and were obtained with a Varian A60 spectrometer. The sweep width was calibrated by the sideband method using an audio oscillator and a frequency counter. The probe was calibrated by comparison with a vibrating quartz thermometer (Dymec 2801 A, Hewlett-Packard), and below 370 °K the corrections were within 1 °K.

Neuman and coworkers (4) also find that the Varian temperatures for the glycol are low. They placed a copper-constantan thermocouple inside a piece of tapered glass tubing sealed at the bottom, and clamped the top of the tube to a ring stand. The tube, which had an outside diameter of ca. 1 mm, was lowered into the spinning sample tube containing glycol. In this way, they find (5): $T = 466.5 - 1.691 |\Delta\nu|$, in excellent agreement with Equation 4.

(4) R. C. Neuman and V. Jonas, *J. Amer. Chem. Soc.*, **90**, 1970 (1968).

(5) R. C. Neuman, University of California, Riverside, private communication, 1968.

PARTS AND ASSEMBLAGES

1. Thermistor (Atkins P99-3, bottom left in Figure 1) with two copper wires (AWG 32, 0.20-mm o.d.), attached. Insulate one of the wires with Teflon "spaghetti" tubing, Size 32, "Thin Wall", 0.28-mm i.d., 0.65-mm o.d., available through electronic and plastic supply houses. Twist the two wires a few turns.

2. Teflon Tube (Figure 1), perfectly straight, Length 221.0 mm, Size 20, "Standard Wall", 0.91-mm i.d., 1.65-mm o.d. Made by Chemplast (150 Dey Rd., Wayne, N. J. 07470) and Alpha Wire (711 Lidgerwood Ave., Elizabeth, N. J. 17207).

Teflon tubing may be straightened by heating at 150 °C for at least 3 days while stretched by 5% or more. After stretching force has been removed, heat for at least 1 hour to remove strain. The brass telescope tubing of Part 3 is convenient to keep the Teflon tube straight while heating.

To prepare the Teflon surface for cementing, the bottom 90 mm is immersed in Chemgrip Treating Agent (Chemplast) which is a suspension of sodium metal. A shortened NMR tube is an ideal container. Wash out and dry. Slide Part 2 over Part 1.

3. Brass Tube, perfectly straight, Length 142.2 mm. Telescope Tubing, 1.65-mm i.d., 2.38-mm o.d.

4. Teflon Tube, perfectly straight, Length 76.2 mm, Size 14, "Lightweight," 1.70-mm i.d., 2.30-mm o.d. Treat 5 mm of the top and the bottom part with Chemgrip Treating Agent. Slide Part 4 over Part 2. Slide Part 3 over Part 2 against Part 4.

5. Brass Supporting Tube (not shown), Length 69 mm, 2.4-mm i.d., 3.2-mm o.d. Slide over Part 4.

6. Identical to Part 5 (not shown). Slide over Part 3.

Apply epoxy cement, Chemgrip-HT (Chemplast), to thermistor and into tubing. Apply cement to the joint of Parts 3 and 4, and into tubing. Be certain the cement does not touch Parts 5 and 6. Cure at 150 °C while keeping Parts 3 and 4 straight.

Starting at 4 mm above the top of Part 2, remove the insulation of the copper wire, as shown in Figure 1. The other wire is cut 20 mm above the top of Part 2.

7. Belden 8700, Miniature Coaxial Cable. Length 1.20 meters. Prepare as shown in Figure 1 at right.

8. Teflon Tube, Length 11 mm, Size 22, "Lightweight," 0.80-mm i.d., 1.15-mm o.d. Slide over inner insulation of Part 7.

9. Teflon Tube, Length 30 mm, Size 12, "Standard Wall," 2.20-mm i.d., 3.00-mm o.d. Prefit over brass tube, 2.38-mm o.d., then slide over Part 7.

10. Teflon Tube, Length 5 mm, Size 12, "Standard Wall." Slide over Part 3.

11. Teflon Tube, Length 35 mm, Size 14, "Lightweight" (see Part 4). Slide over Part 7.

Solder inner conductors together, and slide Part 8 over the joint. Solder the uninsulated wire of Part 1 to the shield of Part 7, leaving small bead of solder. Use minimum heat to avoid damage to polypropylene insulation. Slide Part 11 against Part 3. It should fit snugly over the bead of solder. Slide Part 9 over Part 11, and partially over Part 3.

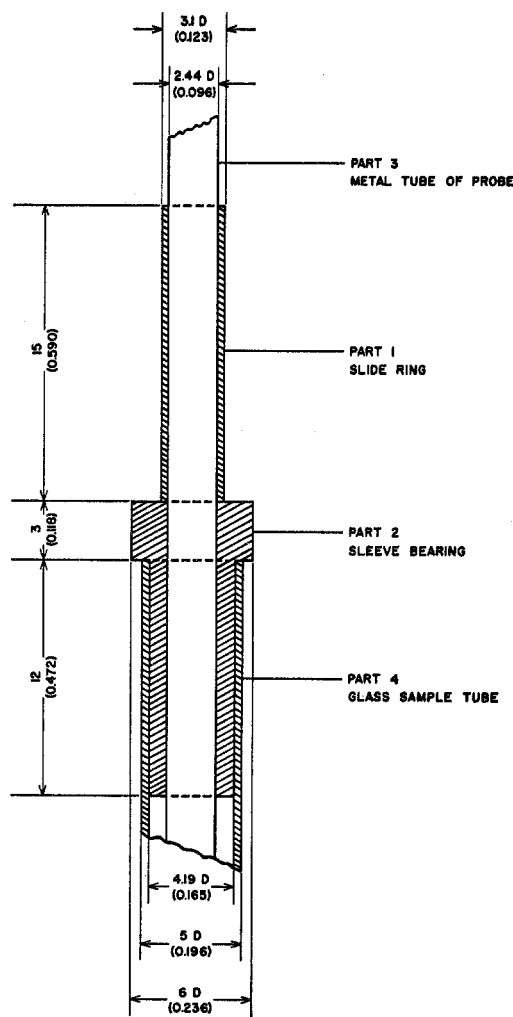

Figure 3. Sleeve bearing for static thermistor probe

Slide ring 1 fits snugly around brass tube 3 of the probe, and sits on the sleeve bearing 2, permitting free rotation. It is made of electrical "spaghetti" tubing of polyperfluoroethylene, size AWG 11, "Standard Wall", i.d. 2.35 mm, o.d. 3.1 mm. The probe 3 fits freely and without any binding in the bearing 2 which is machined out of polyperfluoroethylene

12. Connector (not shown), Amphenol 80-MC2M, 2 pens, shielded. Connect to top of Part 7.

ACKNOWLEDGMENT

The thermistor thermometer clamp was designed and made by Arthur C. Baase.

RECEIVED for review July 15, 1968. Accepted August 26, 1968